



12

## EUROPEAN PATENT SPECIFICATION

45 Date of publication of patent specification :  
17.05.95 Bulletin 95/20

51 Int. Cl.<sup>6</sup> : **H04L 12/28, H04L 12/00**

21 Application number : **88120626.2**

22 Date of filing : **09.12.88**

54 **System for carrying out connection management control of ring network.**

30 Priority : **11.12.87 JP 312315/87**

43 Date of publication of application :  
14.06.89 Bulletin 89/24

45 Publication of the grant of the patent :  
17.05.95 Bulletin 95/20

84 Designated Contracting States :  
**DE FR GB**

56 References cited :  
EP-A- 0 150 907  
IEEE JOURNAL ON SELECTED AREAS IN  
COMMUNICATION. vol. 4, no. 9, December  
1986, NEW YORK US pages 1474 - 1483;  
J.W.REEDY: "The TDM Ring- A Fiber Optic  
Transport System for Campus or Metropolitan  
Networks"  
COMPCON spring 87 February 1987, IEEE  
NEW YORK US pages 434 - 440; F.E.ROSS:  
"FDDI-an Overview"

73 Proprietor : **FUJITSU LIMITED**  
**1015, Kamikodanaka**  
**Nakahara-ku**  
**Kawasaki-shi Kanagawa 211 (JP)**

72 Inventor : **Jinzaki, Akira**  
**2-1-4-111, Tsukimino**  
**Yamato-shi Kanagawa 242 (JP)**  
Inventor : **Higuchi, Masahiro**  
**Sezaaru Musashihinjo 206**  
**1091-8, Kamikodanaka**  
**Nakahara-ku Kawasaki-shi Kanagawa 211**  
**(JP)**

74 Representative : **Lehn, Werner, Dipl.-Ing. et al**  
**Hoffmann, Eitle & Partner,**  
**Patentanwälte,**  
**Postfach 81 04 20**  
**D-81904 München (DE)**

**EP 0 319 998 B1**

Note : Within nine months from the publication of the mention of the grant of the European patent, any person may give notice to the European Patent Office of opposition to the European patent granted. Notice of opposition shall be filed in a written reasoned statement. It shall not be deemed to have been filed until the opposition fee has been paid (Art. 99(1) European patent convention).

## Description

### BACKGROUND OF THE INVENTION

#### 1. Field of the Invention

The present invention relates to a system for carrying out a connection management of a ring network which comprises a plurality of nodes connected in series via a ring line.

In the ring network, a connection management must be effectively performed for stopping the network operation when an abnormality occurs in the network and for restarting the network after the abnormality is eliminated, by determining whether the ring network is correctly formed as a ring through all of the nodes accommodated therein.

Specifically, the present invention refers to a ring network having a ring line, i.e., ring-form data transmission line. The present invention is preferably applied to a network having a single ring line, but as will be understood hereinafter, the present invention is also applicable to a ring network which, although having double ring lines, is often operated as a ring network having a single ring line. The single ring line connects a plurality of nodes, such as terminal stations, to realize a data transmission and reception thereamong. Each node is provided with at least one processor.

In general, the use of double ring lines increases the reliability of a ring network, but a single ring line is sufficient for some ring networks, such as a dispersed multiprocessor system. In such a multiprocessor system, there is little likelihood of damage to the transmission line, i.e., the ring line, compared with the probability thereof in a long distance data transmission system for intercity connections. Accordingly, a single ring line is preferable for such a dispersed multiprocessor system, from an economical view point, when setting up the same as a ring network. The present invention is preferably applied to a single ring line type network, for example, a dispersed multiprocessor system as mentioned above.

#### 2. Description of the Related Art

Two systems for carrying out a connection management of the ring network accommodating a plurality of nodes are known, for example, a token ring system and a fiber distributed data interface (FDDI) system. The former token ring system by IEEE 802.5 is explained in, for example, "ANSI/IEEE Standard for Local Area Networks: Token Ring Access Method and Physical Layer Specifications, April 29, 1985 4. Token Ring Protocols" The latter FDDI system by ANSI is explained in, for example, "FDDI TOKEN RING STATION MANAGEMENT (SMT) DRAFT PROPOSED AMERICAN NATIONAL STANDARD X3T9.5, JULY

25, 1985 6. Connection Management"

These two known connection management systems will be explained hereinafter in more detail, but first the problems caused by these systems will be discussed.

The known token ring system carries out the connection management by turning a particular control frame around the ring network. Therefore, a detection of a fault, i.e., abnormality, and a recognition of an elimination of the abnormality is delayed by a term required for turning the particular control frame around the ring network. Accordingly, the larger the size of the ring network, the longer becomes the above-mentioned term required for the detection of a fault and recognition of the elimination of the abnormality.

Further, when an abnormality occurs at a monitor node for realizing concentrated management of the ring network, a complicated processing must be carried out, which processing includes software processing to enable one of the other normal nodes to be used as a new monitor node. Accordingly, it is difficult to apply the token ring system per se to a ring network operated at a high speed of a transmission rate of over 100 Mb/s, due to an overload of the connection management.

Furthermore, each node of the ring network usually holds information regarding the scale of the network. Therefore, if the network is reconstructed due to, for example, the addition of new nodes, this information also must be renewed at the time of the above-mentioned reconstruction. For example, a timer value used for the detection of a fault and the recognition of the elimination of the abnormality, must be renewed to avoid this inconvenience, it is possible not to renew the timer value, by setting same to cope with the maximum expected scale of the network. Such a measure, however, causes a problem in that the above mentioned term for the fault detection and elimination recognition is unnecessary prolonged in a small scale network.

With regard to the known FDDI system, the connection management is carried out between each two adjacent nodes, and thus the system is equivalent to a dispersion control. In such an FDDI system, it is not necessary to turn control data around the ring network as in the token ring system, and consequently, a high speed management is possible. Also, it is not necessary to form a monitor node as in the token ring system, and accordingly, the control of the FDDI system is simpler than the control of the token ring system.

In the token ring system, however, the system must be formed as a double ring network, and therefore, it is impossible to apply the connection management of the token ring system to the FDDI system as is. If a single ring network is partially formed under the FDDI system, the connection management for the part of the network constituting the single ring net-

work is identical to the connection management of the token ring system, and accordingly, a problem similar to the aforesaid problem of the token ring system is raised.

Another known system is shown in IEEE journal on selected areas in communication Vol. 4 No. 9, Dec. 1986 pages 1474-1483, by J.W. REEDY. It shows distributing alarm signals around the ring, and achieving reconfiguration in the presence of faults. Switching to a standby channel, or forming a folded ring is carried out depending on alarms received from neighbouring nodes.

### SUMMARY OF THE INVENTION

Accordingly, an object of the present invention is to carry out a high speed connection management of a ring network with a simple hardware structure and simple control procedure.

According to the present invention, there is provided a system for carrying out a connection management of a ring network comprised of a plurality of nodes connected in series via a ring line, and provided with a means for determining whether or not to proceed with data communication, using information transmitted from an upstream node, characterized in that each node comprises means for autonomously discriminating a communication status by using both information indicating an own node status and said information from an upstream station, wherein said means for determining whether or not to proceed with data communication in each node operates in accordance with its respective communication status.

Specifically, in a single ring network, the term for reaching a communication enable status at each node is made short when power is supplied to the network and upon recognition of an elimination of an abnormal status of a node. Accordingly, a node places itself in a communication enable status when it has confirmed that at least two upstream nodes are in a normal status, this is achieved without using a monitor node or a supervisory node.

Other independent aspects of the invention are indicated in claims 5, 14 and 21.

### BRIEF DESCRIPTION OF THE DRAWINGS

The above object and features of the present invention will be more apparent from the following description of the preferred embodiments with reference to the accompanying drawings, wherein:

- Fig. 1 illustrates a prior art single ring network;
- Fig. 2 illustrates a prior art double ring network;
- Fig. 3 illustrates a basic construction of a connection management system according to the present invention;
- Fig. 4 is a block diagram showing a first embodiment of a node according to the present inven-

tion;

Fig. 5 is a schematic block diagram of a known synchronous sequential circuit;

Fig. 6 is a block diagram showing the main portion of the connection management unit illustrated in Fig. 4;

Fig. 7 is a block diagram showing a second embodiment of a node according to the present invention;

Fig. 8 is a block diagram showing the main portion of the connection management unit illustrated in Fig. 7;

Fig. 9 depicts various modes of status changes exhibited in each node according to the present invention;

Fig. 10 shows an example of a transmission frame transferred on a ring line;

Fig. 11 illustrates a ring network subjected to the system according to the present invention;

Fig. 12 depicts a time sequence for explaining a normal set up of a ring network;

Fig. 13 depicts a time sequence for explaining a case where an abnormality has occurred;

Fig. 14 depicts a time sequence for explaining a case where an abnormality is repaired and working restarted;

Figs. 15A through 15J are diagrams of the ring network used for explaining the changes of both the status (S) and the control pattern (CP); and, Fig. 16 recites an example of transmission codes transferred on the digital ring line.

### DESCRIPTION OF THE PREFERRED EMBODIMENTS

Before describing the embodiments of the present invention, the related art and the disadvantages therein will be described with reference to the accompanying figures.

Figure 1 illustrates a prior art single ring network. The aforesaid token ring system is applicable to the type of single ring network illustrated in Fig. 1. In this single ring network, a plurality of nodes 71, 72, 73 ..... 7n are connected in a form of a ring via a ring line comprised of a coaxial line, a twisted pair line, and the like. The ring line usually carries out a one-way transfer of data of about 4 Mb/s. One of the nodes, for example, the node 72 is used as the monitor node. The monitor node 72 sends a control frame. The control frame turns around the ring line and returns to the monitor node 72. When the node 72 has confirmed the return of the control frame, the connection management is completed. Accordingly, the ring network is now in a communication enable status, and thus the node 72 transmits a token on the ring line. Whichever node receives the transmitted token can obtain the right to transmit data therefrom. Note, the token is reproduced by the monitor node.

Figure 2 illustrates a prior art double ring network to which the FDDI system is applicable. In this double ring network, a plurality of nodes 81, 82, 83 ..... 8n are connected in the form of a ring via double rings comprised of an optical fiber line and the like. The double rings usually transfer high speed data of about 100 Mb/s, and a two-way data transfer can be made between each two adjacent nodes via the double lines. Accordingly, the connection management can be carried out between two adjacent nodes to finally confirm the establishment of a communication enable status.

In the above explained token ring system and FDDI system shown in Figs. 1 and 2, however, the problems as mentioned previously in detail arise.

In the present invention, the connection management is carried out basically by transmitting from the own node one of several control patterns, selected in accordance with a communication status of the own node, to the downstream node, while receiving and discriminating a control pattern transmitted from the upstream node, to thereby determine a connection status of the related ring network.

Figure 3 illustrates a basic construction of a connection management system according to the present invention. In general, this connection management system employs a means for autonomously discriminating a communication status by using information indicating a status of the own node and information transmitted from the upstream node, and thereby each node itself determines whether or not a data communication is allowed, with the aid of the autonomously discriminating means.

More specifically, in Fig. 1, a plurality of nodes 1 are connected in series via a ring line, i.e., in a ring form. An arbitrary one of the nodes 1 is illustrated in detail. Each node 1 comprises a control pattern transmitting means 2, a control pattern receiving means 3, and a connection management control means 4. The control pattern transmitting means 2 selects one of at least three control patterns and transmits the thus selected control pattern to the downstream node 1. The three control patterns are a first control pattern indicating that the own node 1 is normal, a second control pattern indicating that both the own node 1 and the upstream node 1 are normal, and a third control pattern indicating that an abnormality has occurred. The control pattern receiving means 3 receives the control pattern transmitted from the upstream node and discriminates the nature of the received control pattern. The connection management control means 4 holds a communication status of the own node, changes the held communication status in accordance with the nature of the control pattern received by the control pattern receiving means 3 of the own side, and controls the control pattern transmitting means 2 in accordance with the thus changed communication status.

When an abnormality occurs in the own node or the upstream node or when the own node receives and discriminates the third control pattern indicating that the upstream node is abnormal, the control pattern transmitting means 2 of the own node transmits the third control pattern to the downstream node.

Further, when the own node is normal but there is no confirmation that the ring network as a whole has created an inherent connection status, the control pattern transmitting means 2 transmits the first control pattern to the downstream node.

When the received control pattern is discriminated as the first control pattern, the transmitting means 2 transmits the second control pattern. When the received control pattern is discriminated as the second control pattern, the second control pattern is transmitted to the downstream node. When an abnormal node is restored the control pattern transmitting means of the node repeatedly transmits the second control pattern a plurality of times to the downstream node if the control pattern receiving means of the restored node receives the first control pattern from the upstream node.

When the control pattern receiving means 3 of the node 1 repeatedly receives the second control pattern a predetermined number of times, the connection management control means 4 of this node determines that the ring network, as a whole has created an inherent connection status.

Each of the nodes 1 shown in Fig. 3 has the same construction, and accordingly, operates in the same way and exhibits the same function. Each connection management control means 4 itself determines the aforesaid communication status. The communication status includes, for example, first communication status, i.e., an inspection status in which it is determined whether or not the single line connecting the nodes 1 is formed as a ring; a second communication status, i.e., a connection status in which it is confirmed that the ring line is completed; and, a third communication status, i.e., an abnormality status in which the occurrence of an abnormality is detected and the node waits for the abnormality to be eliminated. The connection management control means 4 changes the above mentioned communication status held therein in accordance with the nature of the control pattern received and discriminated by the control pattern receiving means 3, and then transmits a control pattern corresponding to the thus changed communication status from the control pattern transmitting means to the downstream node.

The third control pattern is transmitted to the downstream node as the aforesaid abnormality status in either one of the following cases: the own node is in an abnormal state; a signal is not received since the upstream node is in an abnormal state; and, the third control pattern transmitted from the upstream node is received. In one the above cases, if the own

node is in a normal state, the first control pattern, following the transmission of the third control pattern, is transmitted to the downstream node.

The inspection state is created after the transmission of the first control pattern, where the own node is normal but there is no confirmation that the ring network as a whole has created the inherent connection status, which corresponds to, for example, a term required for an initial set up of the network, due to a power-ON thereof.

When the control pattern receiving means 3 receives and discriminates the first control pattern, it recognizes that the upstream node is normal, and therefore, the own node transmits the second control pattern to the downstream node. Accordingly, the downstream node is informed, by this second control pattern, that not only the own node but also the upstream node is normal in this case, it the control pattern receiving means 3 again receives and discriminates the first control pattern, the related node transmits the first control pattern to the downstream node. If the control pattern receiving means 3 receives and discriminates the second control pattern, the related own node informs the downstream node that both the own node and the upstream node are normal. Regarding the node 1 which was in the abnormal states but has been restored, when this node receives and discriminates the first control pattern transmitted from the upstream node, the node repeatedly transmits the second control pattern a plurality of times to the downstream node. Therefore, the first control pattern given thereafter from the upstream node is masked and not given to the downstream node. This enables a shortening of the term required for restoring an abnormality. Note, after the transmission of the second control pattern, if the first control pattern is repeatedly transmitted, this first control pattern is transmitted to the downstream node.

When the control pattern receiving means 3 repeatedly receives and discriminates the second control pattern a predetermined number of times, the connection management control means 4 changes the communication status of the own node to the connection status. Namely, the connection management control means 4 determines that the connection status has been created in the ring network, and thus the inherent data communication is started.

Embodiments of the present invention will be described hereinafter by way of examples; first, of the analog signal mode, and then of the digital signal mode.

Figure 4 is a block diagram showing a first embodiment of a node according to the present invention. The node 10, which is a representative of all of the nodes 1 shown in Fig. 3, handles analog signals via an analog signal mode ring line. In the figure, reference numeral 11 denotes a transmitting unit which comprises a signal driver, 12 a receiving unit which

comprises a signal receiver, 13 a switching circuit (SW), 14 a connection management unit, 15 a transmission control unit, 16 a reception control unit, and 17 a data processing unit which comprises at least a microprocessor ( $\mu$ P), memories (ROM, RAM) and a common bus, as well known. The unit 14 comprises a control pattern transmission circuit 18, a control pattern detection circuit 19, and a connection management control unit 20.

According to a pattern command information from the connection management control unit 20, the control pattern transmission circuit 18 produces one of the first control pattern CP1 indicating that the own node is normal, the second control pattern CP2 indicating that both the own node and the upstream node are normal, and the third control pattern CP3 indicating that an abnormality has occurred.

The control pattern detection circuit 19 discriminates the control pattern received from the upstream node to produce pattern analysis information which is transferred to the connection management control unit 20. The control pattern detection circuit 19 informs the connection management control unit 20 if the own node cannot receive a control pattern from the upstream node after an elapse of a predetermined term, by outputting pattern analysis information stating that a control pattern has not been received.

At least three communication statuses are defined in the connection management control unit 20, as follows: A first communication status, i.e., an inspection status in which it is determined whether or not the single line connecting the nodes is formed as a ring; a second communication status, i.e., a connection status in which it is confirmed that the ring line is completed; and, a third communication status, i.e., an abnormality status in which the occurrence of an abnormality is detected and the node waits for a restoration from the abnormality. The communication status defined in the unit 20 is changed in accordance with the pattern analysis information sent from the detection circuit 19, and according to the thus changed communication status, a pattern command information is supplied to the control pattern transmission circuit 18 at each predetermined term T. If a control pattern is not received from the upstream node after an elapse of a predetermined term T, the communication status is changed to the abnormal state, and the third control pattern is output from the control pattern transmission circuit 18 to indicate the occurrence of an abnormality. The above function for defining the communication status is achieved by the connection management control unit 20, and this unit 20 can be realized by, for example, a known synchronous sequential circuit illustrated in Fig. 5.

Figure 5 is a schematic block diagram of a known synchronous sequential circuit. The synchronous segmental circuit functionally comprises a status de-

cision part 7, a status holding part 8, and an output part 9. The status holding part 8 holds the present communication status, i.e., the inspection status, the connection status, and the abnormal state and so on (as explained later). The present communication status is supplied from the status decision part 7 which receives, as an input ("INPUT"), the control pattern CP sent from the upstream node, and further receives the present status information fed back from the present communication status holding part 8. The thus held communication status is produced via the output port 9. This example of the synchronous sequential circuit handles about nine communication statuses, as disclosed later with reference to Figure 9, and handles 4 bit data. In practice, the three parts 7, 8, and 9 can be realized by a known programmable logic array (PLA).

Referring again to Fig. 4, the transmission control unit 15 transfers the received transmission data to the transmitting unit 11 via the switching circuit 13. The switching circuit 13 is controlled by the data processing unit 17 or the transmission control unit 15 to selectively switch between the data transmission mode and the control pattern mode. The reception control unit 16 transfers the data received at the receiving unit 12 to the data processing unit 17, which discriminates whether or not the destination of the received data is the own node. If the destination of the received data is not the own node, the received data is transferred through the unit 17 and sent, via the transmission control unit 15, to the downstream node.

Figure 6 is a block diagram showing the main portion of the connection management unit illustrated in Fig. 4. In Fig. 6, three different frequencies  $f_1$ ,  $f_2$  and  $f_3$  are used as the first, second and third control patterns CP1, CP2 and CP3, respectively. The control pattern transmission circuit 18 is composed of three oscillators 21, 22, and 23 having the frequencies  $f_1$ ,  $f_2$ , and  $f_3$ , and a switch circuit 24. One of the control patterns of the frequencies  $f_1$ ,  $f_2$ , and  $f_3$  is selected by the switch circuit 24, operated in accordance with the pattern command information from the connection management control unit 20, and the thus selected control pattern is transferred to the transmitting unit 11. On the other hand, the control pattern detection circuit 19 is composed of filters 25, 26 and 27 having center frequencies  $f_1$ ,  $f_2$  and  $f_3$ , respectively. If another control pattern is needed, the corresponding pair of oscillator and filter may be used.

In an initial set up of each node, due to a power-on thereof or where an abnormal node is to be restored, the connection management control unit 20 in the corresponding node changes the communication status to the inspection status. During the inspection status, the connection management control unit 20 controls the switch circuit 24 to select the oscillator 21 and to produce the frequency  $f_1$  thereof composing the first control pattern CP1.

When the first control pattern CP1 is received from the upstream node, the pattern CP1 is detected by the filter 25 in the control pattern detection circuit 19. In the above exemplified case, the first control pattern CP1 is received during the inspection status, and thus the connection management control unit 20 controls the switch circuit 24 to select the oscillator 22 to produce the frequency  $f_2$  thereof composing the second control pattern CP2.

If the second control pattern CP2 is repeatedly received a predetermined number of times while the communication status is the inspection status, the unit 20 changes the communication status to the connection status to start the communication enable status. During the communication enable status, the unit 20 controls the switch circuit 24 to select the output frequency  $f_2$ , i.e., the second control pattern CP2.

If an abnormality occurs in a node, the connection management control unit 20 changes the communication status of the own node to the abnormal state and controls the switch circuit 24 to correspond to the abnormal state, and thus the output frequency  $f_3$  of the oscillator 23 is repeatedly transmitted, as the third control pattern CP3. Further, where a control pattern is not sent from the upstream node after an elapse of a predetermined term T, the connection management control unit 20 changes the communication status to the abnormal state and controls the switch circuit 24 to correspond to this state, and accordingly, the switch circuit 24 selects the output frequency  $f_3$  of the oscillator 23 as the third control pattern CP3. In this case, since the own node is normal, the first control pattern CP1 is transmitted after the transmission of the control pattern CP3.

Further, when the third control pattern CP3 is received from the upstream node, the connection management control unit 20 of the own node transmits the third control pattern CP3 and, at the same time, changes the communication status thereof to the inspection status.

Figure 7 is a block diagram showing a second embodiment of a node according to the present invention. The node 30, which is representative of all of the nodes 1 shown in Fig. 3, handles digital signals via a digital signal mode ring line. In the Figure, reference numeral 31 denotes a transmitting unit, 32 a receiving unit, 33 a switch circuit (SW), 34 a connection management unit, 35 a transmission control unit, 36 a reception control unit, 37 a data processing unit which comprises at least a microprocessor ( $\mu$ P), memories (ROM, RAM), and a common bus, as well known, 38 a control pattern transmission circuit, 39 a control pattern detection circuit, 40 a connection management control unit, 41 a parallel/serial converting circuit, 42 a serial/parallel converting circuits, 43 and 44 code conversion circuits which convert the each code of transmitting and receiving data, and 45 a frame detection circuit.

In the second embodiment, the connection management is carried out by a digital processing, but the overall operation of the node 30 is substantially the same as that of the node 10 explained above. The control pattern transmission control circuit 38 is constructed such that the first, second and third control patterns are each composed of a predetermined bits arrangement, and the control pattern detection circuit 39 is constructed such that the first through third control patterns, composed of the above predetermined bits arrangement, can be discriminated from each other. The code conversion circuits 43 and 44 are used, respectively, to convert the code of data from the data processing unit 37 to the code to be transferred on the ring line, and to convert the code on the ring line to the code format suitable to the code for handling by the data processing unit 37. For example, a 4B5B code is utilized for the code conversion by which a 4-bit code is converted to a 5-bit code, and vice versa. The 5-bit code is suitable for a transmission of data, and the 4-bit code is suitable for data processing.

The frame detection circuit 45 detects a frame signal from the data received and recognizes that the node 30 is now receiving data sent from the upstream node, and then informs the connection management control unit 40 of this occurrence, whereupon the unit 40 stops any change of the communication status, since a control pattern is not sent at that moment. Namely, an inherent data communication is to be realized at that stage. The parallel/serial converting circuit 41 converts parallel data or a parallel control pattern output from the switch circuit 33 to serial data or a serial control pattern to be applied to the transmitting unit 41. On the other hand, the serial/parallel converting circuit 42 converts the serial signal received at the receiving unit 32 to a parallel signal to be applied to the control pattern detection circuit 39, the code conversion circuit 44, and the frame detection circuit 45.

Figure 8 is a block diagram showing the main portion of the connection management unit illustrated in Fig. 7. The control pattern transmission circuit 38 comprises a selector 54 and control pattern generating units 51, 52 and 53 each having, for example, a register for storing the first, second and third control patterns CP1, CP2, and CP3, respectively. The control pattern detection circuit 39 comprises control pattern detecting units 55, 56, and 57 each having, for example, a logic gate by which the respective control patterns (CP1, CP2, CP3) are detected.

When the frame signal is detected by the frame detection circuit 45, a set signal is applied therefrom to a flip-flop 47, and a preset signal is applied therefrom to a frame counter 46. The receiving clock contained in the received signal is also applied to the frame counter 46. After the presetting of the frame counter 46 by the preset signal, the counter 46 starts

to count up the count number therein by the receiving clock, and when the count number reaches a number equivalent to the length of one frame of data, the counter 46 applies a reset signal to the flip-flop 47. Accordingly, when the frame signal is detected by the detection circuit 45, the flip-flop 47 is set to produce a logic "1" at the Q output terminal thereof, which is applied to a gate circuit (G) 48 to open the same. The above logic "1" indicates that an inherent data signal is being received at the node. At this time, the status change clock is not allowed to pass through the gate circuit 48 to prevent the communication status from being changed in the connection management control unit 40, since inherent data is being handled. Therefore, the gate circuit 48 prevents a change of the communication status to an erroneous communication status, even if the receiving data partially includes a data pattern which happens to be the same as one of the control patterns.

When the receiving unit 32 receives the serial signal (serial bit signal) from the upstream node, the received serial signal is converted into a parallel signal (parallel bit signal) by the serial/parallel converting circuit 42. The classification of the control pattern contained in the parallel signal is detected by the control pattern detection circuit 39, and the resultant pattern classification information is sent to the connection management control unit 40. Upon receipt of this information, the communication status defined in the unit 40 is changed. The control pattern, selected in accordance with the thus changed communication status is produced from the control pattern transmission circuit 38, when not the timing of the inherent data transmission, the produced control pattern is applied to the parallel/serial converting circuit 41, via the switch circuit 33, for conversion into the serial signal to be sent to the downstream node from the transmitting unit 31.

Note, the various functions achieved in the node can be realized by not only hardware, as disclosed before, but also by software, through a processor. In this case, each node can be represented by a processor to construct a multiprocessor system, as mentioned above, by using a high speed transmission line of over 100 Mb/s as the ring line connecting the processors in the form of a ring.

Figure 9 depicts various modes of status changes exhibited in each node according to the present invention. Namely, the figure shows the transmission and reception of the first, second and third control patterns CP1, CP2, AND CP3 used in the first and second embodiments and the status following a present status by using status modes classified into, for example, nine categories, i.e., S1 through S9.

The inspection status is classified, as an example, into a first status S1 in which the own node is normal, a second status S2 in which both the own node and the upstream node are normal, and a third status

S3 in which the connection of the ring is under confirmation and, therefore, the connection is not yet completed (connection confirmation status). The connection state is represented by a fourth status S4 in which it is confirmed that the ring is normally connected (connection status). The abnormal state is classified, as an example, into a fifth status S5 in which a signal cannot be received from the upstream node a sixth status S6 in which a wait for a restoration from an abnormal state is made, seventh and eighth statuses S7 and S8 in which a signal can be received from the upstream node and the abnormality is restored, and a ninth status S9 in which a warning of an abnormality sent from the upstream node is given to the downstream node.

One of the first, second and third control patterns CP1, CP2, and CP3 is selected in accordance with the various communication statuses S1 through S9, and the communication status is changed to the next status in accordance with the received control patterns CP1, CP2, and CP3. Note that a reception error in the abnormality status S6 denotes that a signal cannot be received from the upstream node. If this signal non-reception state occurs in a state other than the abnormal state S6, the communication status is changed to the abnormality detection status S5.

For example, when the communication status is the connection status S4, during which the second control pattern CP2 is transmitted, and if the second control pattern is received under the same status, the communication status is not changed. But under the same status, if the third control pattern CP3 is received instead of the pattern CP2, the communication status is changed to the abnormality warning status S9. Note the "CP1 and CP2" depicted in the "RECEIVING PATTERN" column crossing the S1 row denote that either the CP1 or CP2 has been received. Similarly, the "RECEPTION ERROR", CP2 and CP3 depicted in the same column crossing the S6 row denote that a reception error or the CP2 or the CP3 exists. The rule shown in Fig 9 is used as a reference in the following explanation of Figs. 12, 13, and 14.

Figure 10 shows an example of a transmission frame transferred on a ring line. Note that the shown transmission frame appears on the digital signal mode ring line, not the analog signal mode ring line. The data to be transmitted ("DATA") is accompanied, at the head and end thereof, by frame delimiter patterns (FDP's) to form one data frame. During the time such a data frame does not exist, the second control pattern CP2 is repeatedly transferred at each predetermined term. This continuous flow of the CP2 enables an easy and rapid detection of an absence of a signal due to an abnormality. Note, the length of the data frame matches the maximum count number of the frame counter 46 shown in Fig. 8.

Figure 11 illustrates a ring network subjected to the system according to the present invention. The

ring network according to the present invention is different from those shown in Figs. 1 and 2, although the ring network of Fig. 1 is similar to that of Fig 11 from the viewpoint of ring structure, i.e., a single ring line, but is different in that the monitor node 72 is required. The ring network of Fig. 2 is similar to that of Fig. 11 from the view point that the monitor node 72 is not required, but has a different ring structure, i.e., double ring lines.

In Fig. 11, nodes N1 through N7 have the same construction as exemplified in Figs. 4 and 7, and are connected in series via, for example, and optical fiber transmission line, to form a ring. In the ring network, when an initial set up of the ring network is commenced, the nodes N1 through N7 are put in the power ON status almost simultaneously. This will be schematically explained below with reference to the figure.

Figure 12 depicts a time sequence for explaining a normal set up of a ring network. Note that this explanation will be made with reference to Figs. 7 and 8, but the same explanation applies to Figs. 4 and 6.

Upon a power ON of the nodes N1 through N7, the status change clock (Fig. 8) is applied to the connection management control unit 40 via the gate circuit 48 at each predetermined term T. If the own node is normal, the communication status is set as the first status S1, which indicates that the own node is normal. In this case, the connection management control unit 40 controls the selector 54 in the control pattern transmission circuit 38 to select the first control pattern CP1 output from the control pattern generating unit 51, and the thus-selected CP1 is transmitted to the downstream node.

Each of the nodes N1 through N7 receives the first control pattern CP1 sent from the respective upstream nodes, and accordingly, each node detects the pattern CP1 at the control pattern detecting unit 55 in the control pattern detection circuit 39. The thus-detected pattern classification information is applied to the connection management control unit 40, and therefore, the communication status is changed, upon the application of the next status change clock, from the first status S1 in which the own node is normal to the second status S2 in which the upstream node is normal. Since the communication status is now the second status S2, at the term 2T (Fig.12), the second pattern CP2 output from the control pattern generating unit 52 in the control pattern transmission circuit 38 is selected by the selector 54 and transmitted to the downstream node. Refer to the right most column of Fig. 9 to obtain an understanding of the status change.

Each of the nodes N1 through N7 receives a signal from the respective upstream nodes and discriminates the second control pattern CP2, and thus the communication status in each node is changed, upon the application of the next status change clock, from



the second status S2, in which the respective upstream node is normal, to the third status S3, i.e., the connection confirmation status. At the term 3T (Fig. 12), each node transmits the second control pattern CP2 to the respective downstream nodes. Further, each of the nodes N1 through N7 receives the signal sent from the respective upstream nodes and discriminates the second control pattern CP2, and thus the communication status in each node is changed, upon the application of the next status change clock, from the third status S3, i.e., the connection confirmation status, to the fourth status S4, i.e., the connection status. At the term 4T (Fig. 12), each node transmits the second control pattern CP2 to the respective downstream nodes. After the term 4T, if the second control pattern CP2 is still received, no change occurs in the communication status at each node, and thus the fourth status S4, i.e., the connection status, is maintained as it is, wherein the second control pattern CP2 is repeatedly transmitted at each predetermined term T as depicted in Fig. 10. Accordingly, four terms (4T) after power ON, the communication status in each node is set to the communication enable status. Note, the four terms (4T) are common to all of the nodes N1 through N7, and further, are not varied regardless of an increase (or decrease) in the number of the nodes.

Figure 13 depicts a time sequence for explaining a case wherein an abnormality has occurred. In the example, an abnormality such as a break in the ring line has occurred between the nodes N1 and N7, shown by a vertical arrow in Fig. 13 and represented by a symbol "X". At this time, each node N1 through N7 transmits the second control pattern CP2 under the fourth status S4, i.e., the connection status. Subsequently, due to the abnormality "X", the node N1 can no longer receive the second control pattern CP2 from the upstream node N7, and thereafter, at the timing of the next status change clock, the connection status of the connection management control unit of the node N1 is changed to the fifth status S5, i.e., the abnormality detection state. Accordingly, at the term 1T (Fig. 13), the selector 54 (Fig. 8) of the node N1 selects the third control pattern CP3 produced from the control pattern generating unit 53 in the control pattern transmission circuit 38, and the CP3 is then transmitted to the relevant downstream node, i.e., N2.

At the next term 2T (Fig. 13), the communication status of the node N1 is changed to the sixth status S6, i.e., the abnormality state. During the status S6, the node 1 transmits the first control pattern CP1 to the downstream node N2, and thereafter, the sixth status S6 is maintained until the node N1 receives a signal from the upstream node N7. During this series of sixth statuses S6, the node N1 repeatedly transmits the first control pattern CP1 at each predetermined term T.

The node N2 receives the signal and discriminates the third control pattern CP3 sent from the node N1 at the term 1T (Fig. 13). Accordingly, the communication status of the node N2 is changed from the fourth status S4, i.e., the connection status, to the ninth status S9, i.e., the abnormality warning status, and transmits the third control pattern CP3 to the downstream node N3 at the term 2T (Fig. 13), and then the communication status of the node N2 is changed to the first status S1, indicating that the own node (N2) is normal. Then, the node N2 continues to receive the first control pattern CP1 only from the node N1, as shown in Fig. 13. If the node N2, during a transmission of CP1 therefrom, receives the first control pattern CP1 from the node N1, the communication status of the node N1 is changed to the second status S2 and the node N2 transmits the second control pattern CP2. Conversely, if the node N2, during a transmission of the second control pattern CP2 therefrom, again receives the first control pattern CP1, the node N1 returns to the first status S1 and the node N2 transmits the first control pattern CP1. Consequently, the communication status of the node N2 is changed to the statuses S1 and S2 alternately, as shown in Fig. 13, and thus the corresponding control patterns CP1 and CP2 are transmitted alternately from the node N1 to the node N2 at each predetermined term T cyclically.

Each of the nodes downstream of the node N2, i.e., N3, N4, N5 and so on, operates in the same way as the node N2, as explained above. Namely, although the communication status of the node N1 is maintained at the sixth status S6, each of the other nodes N2 through N7 repeats the first status S1 indicating that the own node is normal and the second status S2 indicating that both the own node and the node upstream thereof are normal, alternately.

Before the repetition of CP1 and CP2, as shown in Fig. 13, the third control pattern CP3 is propagated from the node N1 to the node N7. Namely, the nodes are sequentially notified of the occurrence of an abnormality by the pattern CP3, and finally operation of the ring network as a whole is stopped. The time needed to stop the working of the ring is  $n \cdot T$ , where  $n$  denotes the number of nodes (in the example,  $n = 7$ ) and  $T$  denotes the predetermined term. The above mentioned series of operations will apply, of course, to a case where an abnormality occurs inside the node and not outside the node, as mentioned above. Namely, the abnormal node will operate in the same way as the node N1.

Figure 14 depicts a time sequence for explaining a case where an abnormality is restored and working is restarted. The abnormality between the nodes N1 and N7 (represented by "X") is assumed to have been restored by an operator. The restored abnormality is represented by "o" in Fig. 14. At this time, the node N1 receives the signal from the upstream node N7

and discriminates the first control pattern CP1, and the communication status of the node N1 is changed from the sixth status S6, i.e., the abnormal state, to the seventh status S7, i.e., the abnormality restored status. Under this status, upon receipt of the first control pattern CP1 sent first from the node N7, the node N1 repeatedly transmits, for example three times, the second control pattern CP2 to the downstream node N2. Namely, the second pattern CP2 is transmitted three times at the terms 1T, 2T and 3T (Fig. 14). In this case, the first control pattern CP1 transmitted from the node N7 at the term 2T is ignored by the node N1, and thus the communication status in the node N1 is changed as follows: to the seventh status S7 at 1T → to the eighth status S8 at 2T → and to the second status S2 at 3T, in this order. The status S7 is the abnormality restored status 1 the status S8 is the abnormality restored status 2 and the status S2 indicates that, in this case, both the nodes N1 and N7 are normal.

At the term 3T in Fig. 14, the node N1 (in S2) receives the second control pattern CP2 from the upstream node N7, and thus thereby the communication status of the node N1 is changed from the second status S2 to the third status S3, i.e., the connection confirmation status. Under the status S3, the node N1 transmits the second control pattern CP2 at the term 4T (Fig. 14) to the downstream node N2. But, at this term 4T, since the node N1 in the status S3 has received the first control pattern CP1 from the node N7, the node N1 is returned to the first status S1 indicating that the own node (N1) is normal. Therefore, the node N1 transmits the first control pattern CP1, at the term 5T (Fig. 14), to the downstream node N2.

The node N2 shown in Fig. 14 is repeatedly, i.e., at least three times, supplied with the second control patterns CP2 from the upstream node N1. Upon reception of the CP2 series, the communication status of the node N2 is changed to, e.g., the first status S1 (N2 is normal) at 1T → to the second status S2 (N2 and N1 are normal) at 2T → to the third status S3 (confirmation of connection) at 3T → and to the fourth status S4 at 4T, in this order. The status S4 is the final connection status. Next, at the term 5T, the node N2 receives the first control pattern CP1 from the node N1. In this case, the node N2 receives the control pattern CP1 under the fourth status S4, i.e., connection status. In this case, the node N2 is returned to the second status S2 (indicating that the node N2 is normal) at the term 6T. At the same time, the node N2 transmits the second control pattern CP2 to the downstream node N3. Namely, the first control pattern CP1 from the node N1 is replaced by the second control pattern CP2.

At the term 7T wherein the node N2 receives the first control pattern CP1 transmitted from the node N1, since the communication status of the node N2 is the third status S3, i.e., the connection confirma-

tion status, the status of the node N2 is changed, at the term 8T, to the first status S1 indicating that the node N2 is normal, and thus the node N2 transmits the first control pattern CP1 to the downstream node N3 at the term 8T. In this case, the thus transmitted control pattern CP1 is received by the node N3 which is now in the fourth status S4, i.e., the connection status. Accordingly, the connection status of the node N3 is changed from S4 to S2 (refer to the rightmost column of Fig. 9). Therefore, the node N3 transmits the second control pattern CP2, at the term 9T, to the downstream node N4. Namely, the first control pattern CP1 from the node N2 (8T) is replaced by the second control pattern CP2 in the node N2 (9T).

The above operation also apply to the remaining nodes N4 through N7, and accordingly, when the second control pattern CP2, transmitted from the node N1 repeatedly (three times) during the abnormality restoration process (1T, 2T, 3T), passes through each downstream node, the first control pattern CP1 at each node is replaced by the second control pattern CP2. Therefore, the number of continuous second control patterns CP2 is  $m \times 2 + 3$ , where  $m$  denotes the number of passed nodes. For example, the second control pattern CP2 passing through the node N3 continues on "9" times (4T through 11T twice). In this example of the ring network (refer to Fig. 11), the number "9" is larger than the number of nodes (N1 through N7), i.e., "7", and therefore, the first control pattern CP1 (refer to Fig. 14) crosspoints of ((5T, N1) and (8T, N2)) is no longer propagated to the downstream nodes N3 through N7.

Therefore, the term from when the node N1 has detected the abnormality restoration to when the connection status S4 is established in the node N4, becomes 6T, i.e.,  $3T + 3T$ , where the former 3T is derived from a propagation delay of the second control pattern CP2 and the latter 3T is derived from the time needed to change from the second status S2 to the fourth status S4, i.e., the connection status. In this way the connection status S4 is confirmed at the nodes N5, N6 and N7 one by one, in this order. Finally, the connection status N4 at the node N3 is confirmed, and thus, at the term 11T, all of the nodes are in the connection status and the operation of the ring network as a whole is restarted.

The processing time required for the initial set up of the ring network, becomes 4T where a power ON of the nodes is made simultaneously, as shown in Fig. 12. Conversely, where a power ON of the nodes is made at different timings, the processing time from a power ON of the last node to when the all of the nodes are in the connection status, becomes substantially equal to the processing time needed for the abnormality restoration, mentioned above. The processing time needed for the abnormality restoration is expressed as  $(3k + 5)T$ , where  $k$  is defined as a minimum integer not lower than when  $k$  satisfies  $2k + 3 >$

n, where n denotes the number of nodes. Accordingly, when n = 7 as in the above example, i.e., k = 2, the processing time for the abnormality restoration becomes 11T as shown in Fig. 14.

Further, the predetermined term T is determined in accordance with various conditions such as the distance between each adjacent node, the time needed for the detection and discrimination of the control pattern (CP), the operation speed of the synchronous sequential circuit (Fig. 5), and so on. Namely, the above conditions are irrelevant to the scale of the related ring network per se. For example, if the distance between the nodes is short, the data transmission speed is high and the operation speed of the synchronous sequential circuit is also high, the predetermined term T can be determined as a very small value.

More specifically, the time for detecting the control pattern (CP) composed of, for example, a 5-bit code, is 40 ns less, for example, a 125 Mb/s transmission ring line; and the transmission delay is about 500 ns under, for example, a distance of 500 m between each two adjacent nodes. Under the above specified conditions, the status change interval performed in the connection management control unit 40 (Figs. 7 and 8), i.e., the predetermined term T, can be determined as about 600 ns (= 40 ns + 500 ns). In this case, the processing time where the number of the nodes is "16" and the total length of the related ring network is 1.6 km, becomes 2.4 to 15.6  $\mu$ s during a normal initial set up of the network; becomes 9.6  $\mu$ s during the term from an occurrence of an abnormality to a stoppage of operations; and becomes 15.6  $\mu$ s during the term from an abnormality restoration to a restarting of the operation of the network. This order ( $\mu$ s) of the processing time can be disregarded, since about 1 ms is needed just to complete a synchronous pull-in operation in an optical signal transmission.

Figures 15A through 15J are diagrams of the ring network, explaining the changes of both the status (S) and the control pattern (CP). The various modes of the status changes and the control patterns shown in Fig. 9 are clarified by the use of the time sequences depicted in the Figs. 12, 13, and Fig. 14. The contents of Fig. 9 can be understood as different from Figs. 12, 13 and 14, by referring to Figs. 15A through 15J. Note that the function according to the present invention explained with reference to Figs. 12, 13, and 14 is basically the same as the function explained with reference to Figs. 15A through 15J. It should be understood that all of the modes revealed in Fig. 9 cannot be expressed through Figs. 15A through 15J, and only representative and important modes are revealed therein. Further, only four nodes N1 through N4 are recited therein for clarification.

Figure 15A represents a mode wherein all the nodes are normal and respective transmissions of the control patterns (CP) are started simultaneously.

Note that the character S when accompanied by a numeral indicates the status previously explained.

Figure 15B represents a mode wherein each node determines by itself that each upstream node is normal.

Figure 15C represents a mode wherein each node determines that each two successive upstream nodes are normal.

Figure 15D represents a mode wherein each node in the connection confirming status S3 receives the control pattern indicating that each upstream node is normal. In this mode, each node is in the communication enable status, and thus the related ring network can start the inherent data transmission.

Figure 15E represents an abnormal status. Namely, a break in the ring line, for example, occurs as indicated by "X". In this case, the reception error occurs in the node N1, which is then put in the abnormality detection status.

Figure 15F represents a mode wherein the communication status of the node N1 is changed from the abnormality detection status S5 to the abnormal state S6. The remaining nodes are in the abnormality warning status.

Figure 15G represents a mode wherein each node determines by itself whether or not it is normal.

Figure 15H represents a mode wherein the abnormality is restored by repairing the break in the ring line, and the communication status of the node N1 is changed from the abnormal state S6 to the abnormality restoration status 1, i.e., S7, as the node N1 has received the control pattern CP1 (indicating that the own node is normal) from the upstream node N4. The control pattern CP1 from the node N4 is then changed to CP2.

Figure 15I represents, in the upper row, a mode wherein the communication status of the node N1 is changed from the abnormality restoration status 1, i.e., S7, to the abnormality restoration status 2, i.e., S8, and in the lower row, represents a mode wherein the communication status of the node N1 is changed from the abnormality restoration status 2, i.e., S8, to the second status S2 indicating that both nodes N1 and N4 are normal.

Figure 15J represents, in the upper row, a mode wherein the communication status of the node N1 is changed to the connection confirmation status S3, by the reception of the second control pattern CP2 from the upstream node N4, and in the lower row, represents a mode wherein all of the nodes are restored to the respective connection statuses S4, which mode is identical to that of Fig. 15D.

Figure 16 shows an example of transmission codes transferred on the digital ring line. Each transmission code in the example is composed by using the 4B5B code mentioned previously. The 5 bit (5B) code can represent 16 (= 2<sup>4</sup>) varieties of inherent data patterns 0 through 15 and three varieties of the con-

control patterns CP1 through CP3, the frame delimiter pattern FDP (refer to Fig. 10), the token pattern and unused pattern; namely, 22 ( $2^5$ ) varieties of codes in all. The 4B5B code is useful for obtaining codes including a plurality of logics "1". As well known, each logic "1" is used to reproduce a clock signal from the received data codes, and therefore, the transmission codes including a balanced logic "1", such as Nos. 2 through 7, 9, 11 through 18 and 20, are allotted to the inherent data patterns.

Regarding the control patterns CP1, CP2, and CP3, since these codes appear irregularly, as understood from Fig. 13, they must be clearly distinguished from each other. To this end the transmission codes of the CP1, CP2, and CP3 must have bit patterns such that first, no bit pattern identical to CP3 exists in any series of 5 bits in the CP1 series or the CP2 series; second, no bit pattern identical to CP2 exists in any series of 5 bits in the CP1 series or the CP3 series; third, no bit pattern identical to CP1 exists in any series of 5 bits in the CP3 series or CP2 series; and finally, no bit pattern identical to CP3 exists in any series of 5 bits in the CP1 and CP2 series appearing alternately, i.e., CP1 → CP2 → CP1 → CP2 → ..., as shown in Figs. 13 and 14. Obviously, if such an identical bit pattern does exist, an erroneous code pattern discrimination has been made.

Nevertheless, the frame delimiter pattern (FDP) includes no logic "1", because the FDP does not appear frequently, and it is more necessary to ensure the extraction of the portion of the data frame (Fig. 10) from the continuous flow of bit patterns.

The first and second embodiments are explained by taking into account the case of a single ring network. But, as previously mentioned in the description, the present invention can be applied to a double ring network, if necessary, by using either one of the related double rings as a single ring. Further, in the embodiments, only three control patterns CP1, CP2 and CP3 are used, but obviously other different control patterns can be used in addition to the CP1, CP2, and CP3. These additional control pattern or patterns may be utilized for a process such as a bypass and the like during the abnormal status. Furthermore, the number of statuses to be changed in the connection management control unit 4, 20, and 40 may be increased in accordance with an increase of the number of control patterns.

As explained above in detail, according to the present invention, the communication status defined in the connection management control unit is changed in accordance with both the nature of the received control pattern and the own node status, and then the corresponding control pattern is selected and transmitted to the downstream node. Accordingly, the connection management such as an operation stoppage for the network, an operation restart, and so on, can be realized with a dispersed control system,

and thus it is possible to control a ring network by a relatively simple procedure, even in, for example, a high speed optical fiber ring network, such as over 100 Mb/s, accommodating a plurality of nodes. Note, the advantages of the present invention are not affected by the scale of the ring network.

## Claims

1. A system for carrying out a connection management of a ring network comprised of a plurality of nodes (1) connected in series via a ring line, and provided with a means (3) for determining whether or not to proceed with data communication, using information transmitted from an upstream node, characterized in that each node comprises means (4) for autonomously discriminating a communication status by using both information indicating an own node status and said information from an upstream station, wherein said means for determining whether or not to proceed with data communication in each node operates in accordance with its respective communication status.
2. A system as set forth in claim 1, wherein said autonomously discriminating means comprises a control pattern transmitting unit (2), a control pattern receiving unit (3) and a connection management control unit (4),
 

said control pattern transmitting unit selectively transmitting one of at least three control patterns, i.e., a first control pattern indicating that the own node is normal, a second control pattern indicating that both the own node and the upstream node are normal and a third control pattern indicating an occurrence of an abnormality, and transmitting the selected control pattern to the downstream node,

said control pattern receiving unit receiving the control pattern transmitted from the upstream node and discriminating the nature of the received control pattern, and

said connection management control unit holding the communication status of the own node; changing the held communication status in accordance with the nature of the control pattern received by said control pattern receiving unit of the own node; and controlling said control pattern transmitting unit of the own node in accordance with the changed in the communication status.
3. A system as set forth in claim 1, wherein said ring network is operated as an analog signal mode network using three analog signals having different predetermined frequencies allotted to said

- first, second and third control patterns, respectively.
4. A system as set forth in claim 1, wherein said ring network is operated as a digital signal mode network using three digital signals having different predetermined transmission codes allotted to said first, second and third control patterns, respectively.
5. A system for carrying out a connection management of a ring network which comprises a plurality of nodes connected in series via a ring line, characterized in that the following at least three control patterns are provided:
- a first control pattern indicating that the own node is normal;
  - a second control pattern indicating that both the own node and the upstream node are normal; and
  - a third control pattern indicating that an abnormality has occurred,
- each of said nodes having a control pattern transmitting means (2) for selectively transmitting one of said three control patterns; to the downstream node;
- a control pattern receiving means (3) for receiving the control pattern transmitted from the upstream node and discriminating the nature of the received control pattern, and
  - a connection management control means (4) for holding the communication status of the own node; changing the held communication status in accordance with the nature of the control pattern received by said control pattern receiving means of the own node; and controlling said control pattern transmitting means of the own node in accordance with the change in the communication status.
6. A system as set forth in claim 5, wherein said control pattern is controlled by said connection management control means to transmitting means to transmit said first control pattern when the own node is normal.
7. A system as set forth in claim 5, wherein when said control pattern receiving means discriminates that the received signal is said first control pattern, and the corresponding control pattern transmitting means then transmits said second control pattern to the downstream node.
8. A system as set forth in claim 5, wherein said connection management control means places the own node in a communication enable status upon receipt of the second control pattern from the upstream node.
9. A system as set forth in claim 5, wherein said control pattern transmitting means transmits said third control pattern to the downstream node when the own node is abnormal and when an abnormality has occurred in the upstream node.
10. A system as set forth in claim 5, wherein said control pattern transmitting means transmits said third control pattern to the downstream node when the own node is in the communication enable status, and at the same time, when an abnormality has occurred in the upstream node or when said third control pattern is transmitted from the upstream node and received at the own node.
11. A system as set forth in claim 5, wherein said third control pattern is transmitted from said control pattern transmitting means of the own node to the downstream node when the own node or the upstream node is abnormal, and when said control pattern receiving means discriminates that the signal received from the upstream node is the third control pattern,
- said control pattern transmitting means transmits said first control pattern to the downstream node, when the own node is normal and confirmation has not been received that the ring network as a whole has created an inherent connection status,
  - said control pattern transmitting means transmits the second control pattern to the downstream node when the control pattern receiving means discriminates that the received signal is the first control pattern, and repeatedly transmits said second control pattern when the abnormality is restored, whereby the corresponding control pattern receiving means receives the first control pattern, and
  - said connection management control means determines that the ring network as a whole has created an inherent connection status.
12. A system as set forth in claim 5, wherein said ring network is operated as an analog signal mode network using three analog signals having different predetermined frequencies allotted to said first, second and third control patterns, respectively.
13. A system as set forth in claim 5, wherein said ring network is operated as a digital signal mode network using three digital signals having different predetermined transmission codes allotted to said first, second and third control patterns, respectively.
14. A system for carrying out a connection manage-

ment of a ring network which comprises a plurality of nodes connected in series via a ring line characterized in that each of said nodes contains:

a control pattern transmitting means (2) for selecting one of three control patterns and transmitting the selected pattern to the downstream node, said three control patterns being, a first control pattern indicating that an own node is normal, a second control pattern indicating that both the own node and the upstream node are normal, and a third control pattern indicating that an abnormality has occurred,

a control pattern receiving means (3) for receiving the control pattern transmitted from the upstream node and discriminating the nature of the received control pattern, and

a connection management control means (4) for holding the communication status of the own node; changing the held communication status in accordance with the nature of the control pattern received by said control pattern receiving means of the own node; and controlling said control pattern transmitting means of the own node in accordance with the change in the communication status.

15. A system as set forth in claim 14, wherein said third control pattern is transmitted from said control pattern transmitting means of the own node to the downstream node when the own node or the upstream node is abnormal, and when said control pattern receiving means discriminates that the signal received from the upstream node is the third control pattern.
16. A system as set forth in claim 14, wherein said control pattern transmitting means transmits said first control pattern to the downstream node, when the own node is normal and confirmation has not been received that the ring network as a whole has created an inherent connection status.
17. A system as set forth in claim 14, wherein  
 said second control pattern is transmitted to the downstream node when said first control pattern is received,  
 said second control pattern is transmitted to the downstream node when said second control pattern is received,  
 said second control pattern is repeatedly transmitted to the downstream node from the node which was abnormal but has been restored, when the restored node receives the first control pattern from the upstream node.
18. A system as set forth in claim 14, wherein, said connection management control means determines that the ring network as a whole, has created

an inherent connection status, when the node receives said second control patterns repeatedly transmitted.

- 5 19. A system as set forth in claim 14, wherein said ring network is operated as an analog signal mode network using three analog signals having different predetermined frequencies allotted to said first, second and third control patterns, respectively.
- 10
20. A system as set forth in claim 14, wherein said ring network is operated as a digital signal mode network using three digital signals having different predetermined transmission codes allotted to said first, second and third control patterns, respectively.
- 15
21. A system for carrying out a connection management of a ring network which comprises a plurality of nodes connected in series via a ring line, characterized in that each of said nodes contains:  
 a control pattern transmitting unit (2) which selects one of three control patterns and transmits the selected pattern to the downstream node, said three control patterns being, a first control pattern indicating that an own node is normal, a second control pattern indicating that both the own node and the upstream node are normal, and a third control pattern indicating that an abnormality has occurred,  
 a control pattern receiving unit (3) which receives the control pattern transmitted from the upstream node and discriminates the nature of the received control pattern, and  
 a connection management control unit (4) which holds the communication status of the own node; changes the held communication status in accordance with the nature of the control pattern received by said control pattern receiving unit of the own node; and controls said control pattern transmitting unit of the own node in accordance with the change in the communication status,  
 further said control pattern transmitting unit transmits, said third control pattern to the downstream node, when the own node or the upstream node is abnormal, and when said control pattern receiving unit discriminates that the signal received from the upstream node is the third control pattern,  
 said control pattern transmitting unit transmits said first control pattern to the downstream node, when the own node is normal and confirmation has not been received that the ring network as a whole has created an inherent connection status,  
 said control pattern transmitting unit transmits said second control pattern to the
- 20
- 25
- 30
- 35
- 40
- 45
- 50
- 55

downstream node when said first control pattern is received, and said second control pattern is transmitted repeatedly to the downstream node when the own node which was abnormal and has been restored receives the first control pattern from the upstream node,

furthermore said connection management control units determines that the ring network as a whole has created an inherent connection status when the node receives said second control patterns repeatedly transmitted.

### Patentansprüche

1. System zur Durchführung eines Verbindungsmanagements eines Ringnetzes mit einer Vielzahl von Knoten (1), die über eine Ringleitung in Reihe geschaltet sind und mit einer Einrichtung (3) zur Bestimmung, ob sie mit Datenkommunikation zu betreiben sind oder nicht unter Verwendung einer von einem stromauf gelegenen Knoten übertragenen Information, versehen sind, dadurch gekennzeichnet, daß jeder Knoten eine Einrichtung (4) zur eigenständigen Unterscheidung eines Kommunikationszustandes unter Verwendung sowohl einer Information, die einen eigenen Knotenzustand angibt, als auch der Information von der stromauf gelegenen Station aufweist, wobei diese Einrichtung zur Bestimmung, ob sie mit Datenkommunikation zu betreiben ist oder nicht, in jedem Knoten in Übereinstimmung mit seinem betreffenden Kommunikationszustand arbeitet.
2. System nach Anspruch 1, bei dem die Einrichtung zur eigenständigen Unterscheidung eine Steuermuster-Übertragungseinheit (2), eine Steuermuster-Empfangseinheit (3) und eine Verbindungsmanagement-Steureinheit (4) enthält, die Steuermuster-Übertragungseinheit selektiv eines von mindestens drei Steuermustern überträgt, d.h. ein erstes Steuermuster, welches anzeigt, daß der eigene Knoten normal ist, ein zweites Steuermuster, welches anzeigt, daß sowohl der eigene Knoten als auch der stromauf gelegene Knoten normal sind sowie ein drittes Steuermuster, welches das Auftreten einer Unregelmäßigkeit anzeigt und das selektierte Steuermuster zum stromab gelegenen Knoten überträgt, die Steuermuster-Empfangseinheit das vom stromauf gelegenen Knoten übertragene Steuermuster empfängt und die Art empfangenen Steuermusters feststellt  
und die Verbindungsmanagement-Steureinheit den Kommunikationszustand des eigenen Knotens hält; diesen in Übereinstimmung mit der Art des von der Steuermuster-Empfangseinheit des eigenen Knotens empfangenen Steuer-
3. System nach Anspruch 1, bei dem das Ringnetz als ein Analogsignalmodus-Netz mit drei Analogsignalen mit unterschiedlicher, vorbestimmter, jeweils dem ersten, zweiten und dritten Steuermuster zugeordneter Frequenz betrieben wird.
4. System nach Anspruch 1, bei dem das Ringnetz als ein Digitalsignalmodus-Netz mit drei Digitalsignalen mit unterschiedlichem, vorbestimmtem, jeweils dem ersten, zweiten und dritten Steuermuster zugeordnetem Übertragungscode betrieben wird.
5. System zur Durchführung eines Verbindungsmanagements eines Ringnetzes mit einer Vielzahl von Knoten, die über eine Ringleitung in Reihe geschaltet sind, dadurch gekennzeichnet, daß mindestens die drei folgenden Steuermuster vorgesehen sind:  
ein erstes Steuermuster, welches anzeigt, daß der eigene Knoten normal ist;  
ein zweites Steuermuster, welches anzeigt, daß sowohl der eigene Knoten als auch der stromauf gelegene Knoten normal sind  
und ein drittes Steuermuster, welches anzeigt, daß eine Unregelmäßigkeit aufgetreten ist, wobei jeder der Knoten eine Steuermuster-Übertragungseinrichtung (2) zur selektiven Übertragung eines der drei Steuermuster zur stromab gelegenen Knoten;  
eine Steuermuster-Empfangseinrichtung (3) zum Empfang des vom stromauf gelegenen Knoten übertragenen Steuermusters sowie zur Unterscheidung der Art des empfangenen Steuermusters  
und eine Verbindungsmanagement-Steureinrichtung (4) zum Halten des Kommunikationszustandes des eigenen Knotens; Ändern des gehaltenen Kommunikationszustandes in Übereinstimmung mit der Art des von der Steuermuster-Empfangseinheit des eigenen Knotens empfangenen Steuermusters und zum Steuern der Steuermuster-Übertragungseinheit des eigenen Knotens in Übereinstimmung mit der Änderung des Kommunikationszustandes aufweist.
6. System nach Anspruch 5, bei dem das Steuermuster durch die Verbindungsmanagement-Steureinrichtung so gesteuert wird, daß das erste Steuermuster übertragen wird, wenn der eigene Knoten normal ist.
7. System nach Anspruch 5, bei dem die Steuermuster-

- ster-Empfangseinrichtung feststellt, daß das empfangene Signal das erste Steuermuster ist und die entsprechende Steuermuster-Übertragungseinrichtung dann das zweite Steuermuster zum stromab gelegenen Knoten überträgt.
8. System nach Anspruch 5, bei dem die Verbindungsmanagement-Steuereinrichtung nach dem Empfang des zweiten Steuermusters vom stromauf gelegenen Knoten, den eigenen Knoten in einen eine Kommunikation ermöglichenden Zustand versetzt.
9. System nach Anspruch 5, bei dem die Steuermuster-Übertragungseinrichtung das dritte Steuermuster zum stromab gelegenen Knoten überträgt, wenn der eigene Knoten unregelmäßig ist oder wenn im stromauf gelegenen Knoten eine Unregelmäßigkeit aufgetreten ist.
10. System nach Anspruch 5, bei dem die Steuermuster-Übertragungseinrichtung das dritte Steuermuster zum stromab gelegenen Knoten überträgt, wenn sich der eigene Knoten in einem die Kommunikation ermöglichendem Zustand befindet und gleichzeitig im stromauf gelegenen Knoten eine Unregelmäßigkeit aufgetreten ist oder wenn das dritte Steuermuster vom stromauf gelegenen Knoten übertragen und im eigenen Knoten empfangen wird.
11. System nach Anspruch 5, bei dem das dritte Steuermuster von der Steuermuster-Übertragungseinrichtung des eigenen Knotens zum stromab gelegenen Knoten übertragen wird, wenn der eigene Knoten oder der stromauf gelegene Knoten unregelmäßig ist und wenn die Steuermuster-Empfangseinrichtung feststellt, daß das vom stromauf gelegenen Knoten empfangene Signal das dritte Steuermuster ist, die Steuermuster-Übertragungseinrichtung das erste Steuermuster zum stromab gelegenen Knoten überträgt, wenn der eigene Knoten normal ist und die Bestätigung empfangen worden ist, daß das Ringnetz als Ganzes einen inneren Verbindungszustand aufgebaut hat, die Steuermuster-Übertragungseinrichtung das zweite Steuermuster zum stromab gelegenen Knoten überträgt, wenn die Steuermuster-Empfangseinrichtung feststellt, daß das empfangene Signal das erste Steuermuster ist und das zweite Steuermuster wiederholt überträgt, wenn die Unregelmäßigkeit behoben ist, wodurch die entsprechende Steuermuster-Empfangseinrichtung das erste Steuermuster empfängt  
und die Verbindungsmanagement-Steuereinrichtung feststellt, daß das Ringnetz als Ganzes einen inneren Verbindungszustand aufge-
- baut hat.
12. System nach Anspruch 5, bei dem das Ringnetz als ein Analogsignalmodus-Netz mit drei Analogsignalen mit unterschiedlicher, vorbestimmter, jeweils dem ersten, zweiten und dritten Steuermuster zugeordneter Frequenz betrieben wird.
13. System nach Anspruch 5, bei dem das Ringnetz als ein Digitalsignalmodus-Netz mit drei Digitalsignalen mit unterschiedlichem, vorbestimmten, jeweils dem ersten, zweiten und dritten Steuermuster zugeordnetem Übertragungscode betrieben wird.
14. System zur Durchführung eines Verbindungsmanagements eines Ringnetzes mit einer Vielzahl von Knoten, die über eine Ringleitung in Reihe geschaltet sind, dadurch gekennzeichnet, daß jeder der Knoten enthält:  
eine Steuermuster-Übertragungseinrichtung (2) zum Selektieren eines von drei Steuermustern und Übertragen des selektierten Musters zum stromab gelegenen Knoten, wobei diese drei Steuermuster ein erstes Steuermuster, welches anzeigt, daß der eigene Knoten normal ist, ein zweites Steuermuster, welches anzeigt, daß sowohl der eigene Knoten als auch der stromauf gelegene Knoten normal sind und ein drittes Steuermuster, welches anzeigt, daß eine Unregelmäßigkeit aufgetreten ist, sind,  
eine Steuermuster-Empfangseinrichtung (3) zum Empfang des vom stromauf gelegenen Knoten übertragenen Steuermusters und zur Unterscheidung der Art des empfangenen Steuermusters  
und eine Verbindungsmanagement-Steuereinrichtung (4) zum Halten des Kommunikationszustandes des eigenen Knotens; Ändern des gehaltenen Kommunikationszustandes in Übereinstimmung mit der Art des von der Steuermuster-Empfangseinrichtung des eigenen Knotens empfangenen Steuermusters und zum Steuern der Steuermuster-Übertragungseinrichtung des eigenen Knotens in Übereinstimmung mit der Änderung des Kommunikationszustandes.
15. System nach Anspruch 14, bei dem das dritte Steuermuster von der Steuermuster-Übertragungseinrichtung des eigenen Knotens zum stromab gelegenen Knoten übertragen wird, wenn der eigene Knoten oder stromauf gelegene Knoten unregelmäßig ist und wenn die Steuermuster-Empfangseinrichtung feststellt, daß das vom stromauf gelegenen Knoten empfangene Signal das dritte Steuermuster ist.
16. System nach Anspruch 14, bei dem die Steuer-



- muster-Übertragungseinrichtung das erste Steuermuster zum stromab gelegenen Knoten überträgt, wenn der eigene Knoten normal ist und die Bestätigung, daß das Ringnetz als einen inneren Verbindungszustand aufgebaut hat, nicht empfangen worden ist.
17. System nach Anspruch 14, bei dem das zweite Steuermuster zum stromab gelegenen Knoten übertragen wird, wenn das erste Steuermuster empfangen wird, das zweite Steuermuster zum stromab gelegenen Knoten übertragen wird, wenn das zweite Steuermuster empfangen wird, das zweite Steuermuster von dem Knoten, welcher unregelmäßig war, aber die Unregelmäßigkeit behoben worden ist, wiederholt zum stromab gelegenen Knoten übertragen wird, wenn jener das erste Steuermuster vom stromauf gelegenen Knoten empfängt.
18. System nach Anspruch 14, bei dem die Verbindungsmanagement-Steuereinrichtung feststellt, daß das Ringnetz als Ganzes einen inneren Verbindungszustand aufgebaut hat, wenn der Knoten das wiederholt übertragene zweite Steuermuster empfängt.
19. System nach Anspruch 14, bei dem das Ringnetz als eine Analo­gsignalmodus-Netz mit drei Analogsignalen unterschiedlicher, vorbestimmter, jeweils dem ersten, zweiten und dritten Steuermuster zugeordneter Frequenz betrieben wird.
20. System nach Anspruch 14, bei dem das Ringnetz als ein Digital­signalmodus-Netz mit drei Digitalsignalen mit unterschiedlichem, vorbestimmten, jeweils dem ersten, zweiten und dritten Steuermuster zugeordnetem Übertragungscode betrieben wird.
21. System zur Durchführung eines Verbindungsmanagements eines Ringnetzes mit einer Vielzahl von Knoten, die über eine Ringleitung in Reihe geschaltet sind, dadurch gekennzeichnet, daß jeder Knoten enthält eine Steuermuster-Übertragungseinheit (2), welche eines der drei Steuermuster selektiert und das selektierte Muster zum stromab gelegenen Knoten überträgt, wobei diese drei Steuermuster ein erstes Steuermuster, welches anzeigt, daß der eigene Knoten normal ist, ein zweites Steuermuster, welches anzeigt, daß sowohl der eigene Knoten als auch der stromauf gelegene Knoten normal sind und ein drittes Steuermuster, welches anzeigt, daß eine Unregelmäßigkeit aufgetreten ist, sind, eine Steuermuster-Empfangseinheit (3), welche

das vom stromauf gelegenen Knoten übertragene Steuermuster empfängt und die Art des empfangenen Steuermusters unterscheidet und eine Verbindungsmanagement-Steuereinheit (4), welche den Kommunikationszustand des eigenen Knotens hält; den gehaltenen Kommunikationszustand in Übereinstimmung mit der Art des von der Steuermuster-Empfangseinheit des eigenen Knotens empfangenen Steuermusters ändert und Steuermuster-Übertragungseinheit des eigenen Knotens in Übereinstimmung mit der Änderung des Kommunikationszustandes steuert, die Steuermuster-Übertragungseinheit ferner das dritte Steuermuster zum stromab gelegenen Knoten überträgt, wenn der eigene Knoten oder der stromauf gelegene Knoten unregelmäßig ist und wenn die Steuermuster-Empfangseinheit feststellt, daß das vom stromauf gelegenen Knoten empfangene Signal das dritte Steuermuster ist, die Steuermuster-Übertragungseinheit das erste Steuermuster zum stromab gelegenen Knoten überträgt, wenn der eigene Knoten normal ist und die Bestätigung empfangen worden ist, daß das Ringnetz als Ganzes einen inneren Verbindungszustand aufgebaut hat, die Steuermuster-Übertragungseinheit das zweite Steuermuster zum stromab gelegenen Knoten überträgt, wenn das erste Steuermuster empfangen wird und das zweite Steuermuster wiederholt zum stromab gelegenen Knoten übertragen wird, wenn der eigene Knoten, der unregelmäßig war und dieses behoben wurde, das erste Steuermuster vom stromauf gelegenen Knoten empfängt und die Verbindungsmanagement-Steuereinheit ferner feststellt, daß das Ringnetz als Ganzes einen inneren Verbindungszustand aufgebaut hat, wenn der Knoten das wiederholt übertragene zweite Steuermuster empfängt.

## Revendications

1. Système pour exécuter la gestion de connexions d'un réseau en anneau constitué d'une multitude de noeuds (1) connectés en série via une ligne en anneau, et comportant un moyen (3) pour déterminer si oui ou non il y a lieu de poursuivre la communication de données, utilisant une information transmise à partir d'un noeud situé en amont, caractérisé en ce que chaque noeud comprend un moyen (4) pour discerner de manière autonome un état de communication en employant à la fois une information indiquant son propre état du noeud et ladite information provenant d'une station située en amont, où ledit moyen pour déterminer si oui ou non il y a lieu de

poursuivre la communication des données dans chaque noeud fonctionne en conformité avec son état de communication respectif.

2. Système selon la revendication 1, dans lequel ledit moyen de discernement autonome comprend une unité (2) de transmission de profil de commande, une unité (3) de réception de profil de commande et une unité (4) de commande de gestion de connexions,
  - ladite unité de transmission de profil de commande transmettant sélectivement l'un d'au moins trois motifs de commande, c'est-à-dire un premier profil de commande indiquant que le noeud propre est normal, un second profil de commande indiquant que le noeud propre ainsi que le noeud situé en amont sont normaux et un troisième profil de commande indiquant l'apparition d'une anomalie, et transmettant le profil de commande sélectionné au noeud placé en aval,
  - ladite unité de réception de profil de commande recevant le profil de commande transmis à partir du noeud situé en amont et discernant la nature du profil de commande reçu, et
  - ladite unité de commande de la gestion des connexions maintenant l'état de communication du noeud propre; changeant l'état de communication maintenu en conformité avec la nature du profil de commande reçu par ladite unité de réception de profil de commande du noeud propre; et commandant ladite unité de transmission de profil de commande du noeud propre en conformité avec le changement de l'état de la communication.
3. Système selon la revendication 1, dans lequel ledit réseau en anneau fonctionne comme un réseau au mode à signaux analogiques utilisant trois signaux analogiques ayant des fréquences différentes prédéterminées qui sont allouées auxdits premier, second et troisième profils de commande, respectivement.
4. Système selon la revendication 1, dans lequel ledit réseau en anneau fonctionne comme un réseau au mode à signaux numériques utilisant trois signaux numériques ayant des codes de transmission différents prédéterminés qui sont alloués auxdits premier, second et troisième profils de commande, respectivement.
5. Système pour exécuter la gestion des connexions d'un réseau en anneau qui comprend une multitude de noeuds connectés en série via une ligne en anneau, caractérisé en ce qu'on fournit au moins les trois profils de commande suivants :
  - un premier profil de commande indiquant

que le noeud propre est normal;

un second profil de commande indiquant que le noeud propre ainsi que le noeud situé en amont sont normaux;

un troisième profil de commande indiquant qu'une anomalie s'est produite,

chacun desdits noeuds ayant un moyen (2) de transmission de profil de commande afin de transmettre sélectivement l'un desdits trois profils de commande au noeud placé en aval;

un moyen (3) de réception de profil de commande afin de recevoir le profil de commande transmis à partir du noeud situé en amont et de discerner la nature du profil de commande reçu, et

un moyen (4) de commande de la gestion des connexions pour maintenir l'état de communication du noeud propre; changer l'état de communication maintenu en conformité avec la nature du profil de commande reçu par ledit moyen de réception de profil de commande du noeud propre; et commander ledit moyen de transmission de profil de commande du noeud propre en conformité avec le changement de l'état de la communication.

6. Système selon la revendication 5, dans lequel ledit profil de commande est commandé par ledit moyen de commande de la gestion des connexions afin de transmettre ledit premier profil de commande lorsque le noeud propre est normal.
7. Système selon la revendication 5, dans lequel, lorsque ledit moyen de réception de profil de commande discerne que le signal reçu est ledit premier profil de commande, le moyen de transmission de profil de commande correspondant transmet alors ledit second motif de commande au noeud placé en aval.
8. Système selon la revendication 5, dans lequel ledit moyen de commande de la gestion des connexions place le noeud propre dans un état permettant la communication lors de la réception du second profil de commande en provenance du noeud situé en amont.
9. Système selon la revendication 5, dans lequel ledit moyen de transmission de profil de commande transmet ledit troisième profil de commande au noeud placé en aval lorsque le noeud propre est anormal et lorsqu'une anomalie s'est produite dans la noeud situé en amont.
10. Système selon la revendication 5, dans lequel ledit moyen de transmission de profil de commande transmet ledit troisième profil de commande

au noeud placé en aval lorsque le noeud propre est dans l'état permettant la communication, et en même temps, lorsqu'une anomalie s'est produite dans le noeud situé en amont ou lorsque ledit troisième profil de commande est en transmission à partir du noeud situé en amont et en réception au noeud propre.

11. Système selon la revendication 5, dans lequel ledit troisième profil de commande est en transmission entre ledit moyen de transmission de profil de commande du noeud propre et le noeud placé en aval lorsque le noeud propre ou le noeud situé en amont sont anormaux, et lorsque ledit moyen de réception de profil de commande discerne que le signal reçu qui provient du noeud situé en amont est le troisième profil de commande,

ledit moyen de transmission de profil de commande transmet ledit premier profil de commande au noeud placé en aval, lorsque le noeud propre est normal et que la confirmation n'a pas été reçue du fait que le réseau en anneau dans son ensemble a créé un état de connexion inhérent,

ledit moyen de transmission de profil de commande transmet le second profil de commande au noeud placé en aval lorsque le moyen de réception de profil de commande discerne que le signal reçu est le premier profil de commande, et transmet de façon répétée ledit second profil de commande lorsque l'anomalie est rétablie, d'où il résulte que le moyen de réception de profil de commande correspondant reçoit le premier profil de commande, et

ledit moyen de commande de la gestion des connexions détermine que le réseau en anneau dans son ensemble a créé un état de connexion inhérent.

12. Système selon la revendication 5, dans lequel ledit réseau en anneau fonctionne comme un réseau au mode à signaux analogiques utilisant trois signaux analogiques ayant des fréquences différentes prédéterminées qui sont allouées auxdits premier, second et troisième profils de commande, respectivement.

13. Système selon la revendication 5, dans lequel ledit réseau en anneau fonctionne comme un réseau au mode à signaux numériques utilisant trois signaux numériques ayant des codes de transmission différents prédéterminés qui sont alloués auxdits premier, second et troisième profils de commande, respectivement.

14. Système pour exécuter la gestion des connexions d'un réseau en anneau qui comprend une multitude de noeuds connectés en série via

une ligne en anneau, caractérisé en ce que chacun desdits noeuds contient :

un moyen (2) de transmission de profil de commande pour sélectionner l'un de trois profils de commande et transmettre le profil sélectionné au noeud placé en aval, lesdits trois profils de commande étant : un premier profil de commande indiquant qu'un noeud propre est normal, un second profil de commande indiquant que le noeud propre ainsi que le noeud situé en amont sont normaux, et un troisième profil de commande indiquant qu'une anomalie s'est produite,

un moyen (3) de réception de profil de commande afin de recevoir le profil de commande transmis à partir du noeud situé en amont et discerner la nature du profil de commande reçu, et

un moyen (4) de commande de la gestion des connexions pour maintenir l'état de communication du noeud propre; changer l'état maintenu de la communication en conformité avec la nature du profil de commande reçu par ledit moyen de réception de profil de commande du noeud propre; et commander ledit moyen de transmission de profil de commande du noeud propre en conformité avec le changement de l'état de la communication.

15. Système selon la revendication 14, dans lequel ledit troisième profil de commande est transmis dudit moyen de transmission de profil de commande du noeud propre au noeud placé en aval lorsque le noeud propre ou le noeud situé en amont sont anormaux, et lorsque ledit moyen de réception de profil de commande discerne que le signal reçu en provenance du noeud situé en amont est le troisième profil de commande.

16. Système selon la revendication 14, dans lequel ledit moyen de transmission de profil de commande transmet ledit premier profil de commande au noeud placé en aval, lorsque le noeud propre est normal et que la confirmation n'a pas été reçue du fait que le réseau en anneau dans son ensemble a créé un état de connexion inhérent.

17. Système selon la revendication 14, dans lequel : ledit second profil de commande est transmis au noeud placé en aval lorsque ledit premier profil de commande est reçu,

ledit second profil de commande est transmis au noeud placé en aval lorsque ledit second profil de commande est reçu,

ledit second profil de commande est transmis de façon répétée au noeud placé en aval à partir du noeud qui était anormal mais n'a pas été rétabli, lorsque le noeud rétabli reçoit le premier

- profil de commande en provenance du noeud situé en amont.
18. Système selon la revendication 14, dans lequel ledit moyen de commande de la gestion des connexions détermine le fait que le réseau en anneau dans son ensemble a créé un état de connexion inhérent, lorsque le noeud reçoit lesdits seconds profils de commande transmis de manière répétée. 5
19. Système selon la revendication 14, dans lequel ledit réseau en anneau fonctionne comme un réseau au mode à signaux analogiques en utilisant trois signaux analogiques ayant des fréquences différentes prédéterminées qui sont allouées auxdits premier, second et troisième profils de commande, respectivement. 10
20. Système selon la revendication 14, dans lequel ledit réseau en anneau fonctionne comme un réseau au mode à signaux numériques utilisant trois signaux numériques ayant des codes de transmission différents prédéterminés qui sont alloués auxdits premier, second et troisième profils de commande, respectivement. 15
21. Système pour exécuter la gestion des connexions d'un réseau en anneau qui comprend une multitude de noeuds connectés en série via une ligne en anneau, caractérisé en ce que chacun desdits noeuds contient : 20
- une unité (2) de transmission de profil de commande qui sélectionne l'un de trois profils de commande et transmet le profil sélectionné au noeud placé en aval, lesdits trois profils de commande étant : un premier profil de commande indiquant qu'un noeud propre est normal, un second profil de commande indiquant que le noeud propre ainsi que le noeud situé en amont sont normaux, et un troisième profil de commande indiquant qu'une anomalie c'est produite, 25
- une unité (3) de réception de profil de commande qui reçoit le profil de commande transmis à partir du noeud situé en amont et discerne la nature du profil de commande reçu, et 30
- une unité (4) de commande de la gestion des connexions qui maintient l'état de communication du noeud propre; change l'état maintenu de la communication en conformité avec la nature du profil de commande reçu par ladite unité de réception de profil de commande du noeud propre; et commande ladite unité de transmission de profil de commande du noeud propre en conformité avec le changement de l'état de la communication, 35
- en outre, ladite unité de transmission de profil de commande transmet ledit troisième pro- 40
- fil de commande au noeud placé en aval, lorsque le noeud propre ou le noeud situé en amont sont anormaux, et lorsque ladite unité de réception de profil de commande discerne que le signal reçu en provenance du noeud situé en amont est le troisième profil de commande, 45
- ladite unité de transmission de profil de commande transmet ledit premier profil de commande au noeud placé en aval, lorsque le noeud propre est normal et que la confirmation n'a pas été reçue du fait que le réseau en anneau dans son ensemble a créé un état de connexion inhérent, 50
- ladite unité de transmission de profil de commande transmet ledit second profil de commande au noeud placé en aval lorsque ledit premier profil de commande est reçu, et ledit second profil de commande est transmis de façon répétée au noeud placé en aval lorsque le noeud propre qui était anormal et a été rétabli reçoit le premier profil de commande en provenance du noeud situé en amont, 55
- en outre, ladite unité de commande de la gestion des connexions détermine le fait que le réseau en anneau dans son ensemble a créé un état de connexion inhérent lorsque le noeud reçoit lesdits seconds profils de commande transmis de façon répétée. 20

fil de commande au noeud placé en aval, lorsque le noeud propre ou le noeud situé en amont sont anormaux, et lorsque ladite unité de réception de profil de commande discerne que le signal reçu en provenance du noeud situé en amont est le troisième profil de commande,

ladite unité de transmission de profil de commande transmet ledit premier profil de commande au noeud placé en aval, lorsque le noeud propre est normal et que la confirmation n'a pas été reçue du fait que le réseau en anneau dans son ensemble a créé un état de connexion inhérent,

ladite unité de transmission de profil de commande transmet ledit second profil de commande au noeud placé en aval lorsque ledit premier profil de commande est reçu, et ledit second profil de commande est transmis de façon répétée au noeud placé en aval lorsque le noeud propre qui était anormal et a été rétabli reçoit le premier profil de commande en provenance du noeud situé en amont,

en outre, ladite unité de commande de la gestion des connexions détermine le fait que le réseau en anneau dans son ensemble a créé un état de connexion inhérent lorsque le noeud reçoit lesdits seconds profils de commande transmis de façon répétée.

Fig. 1

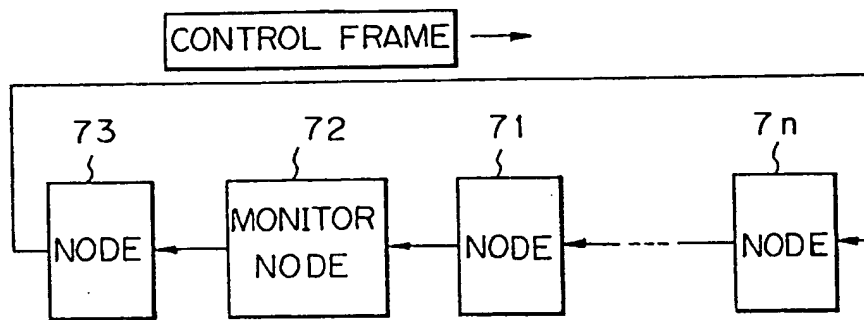

Fig. 2

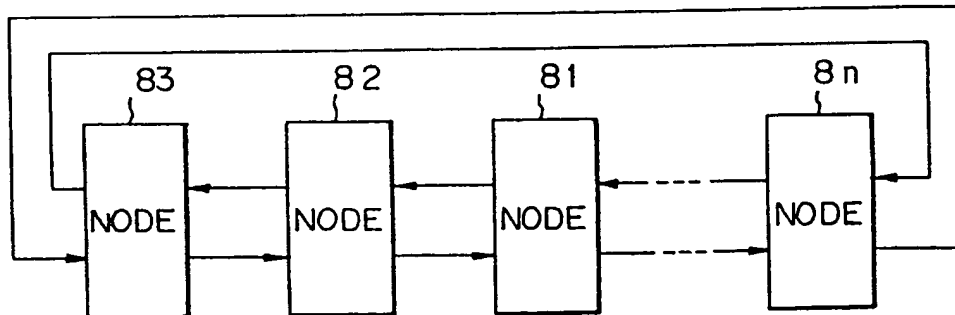

Fig. 3

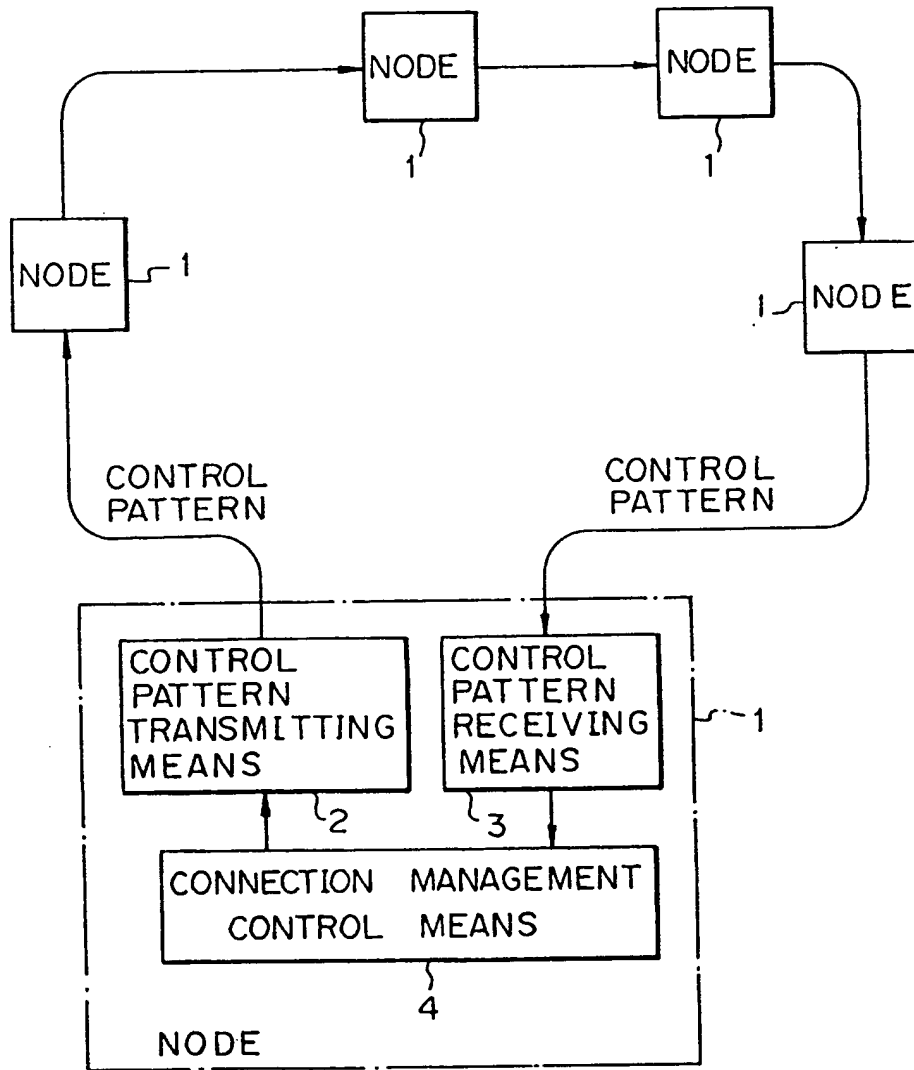

Fig. 4

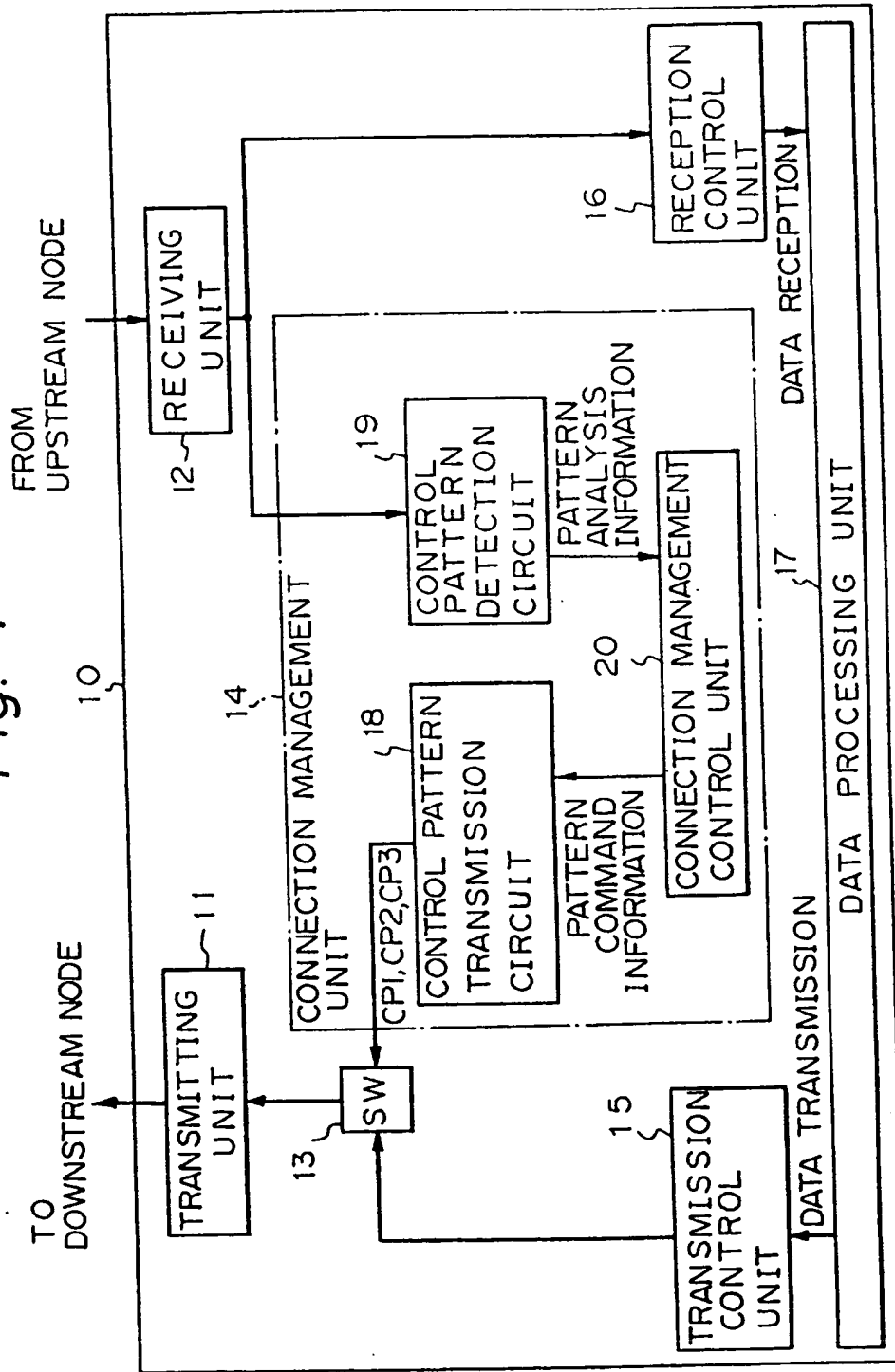

Fig. 5

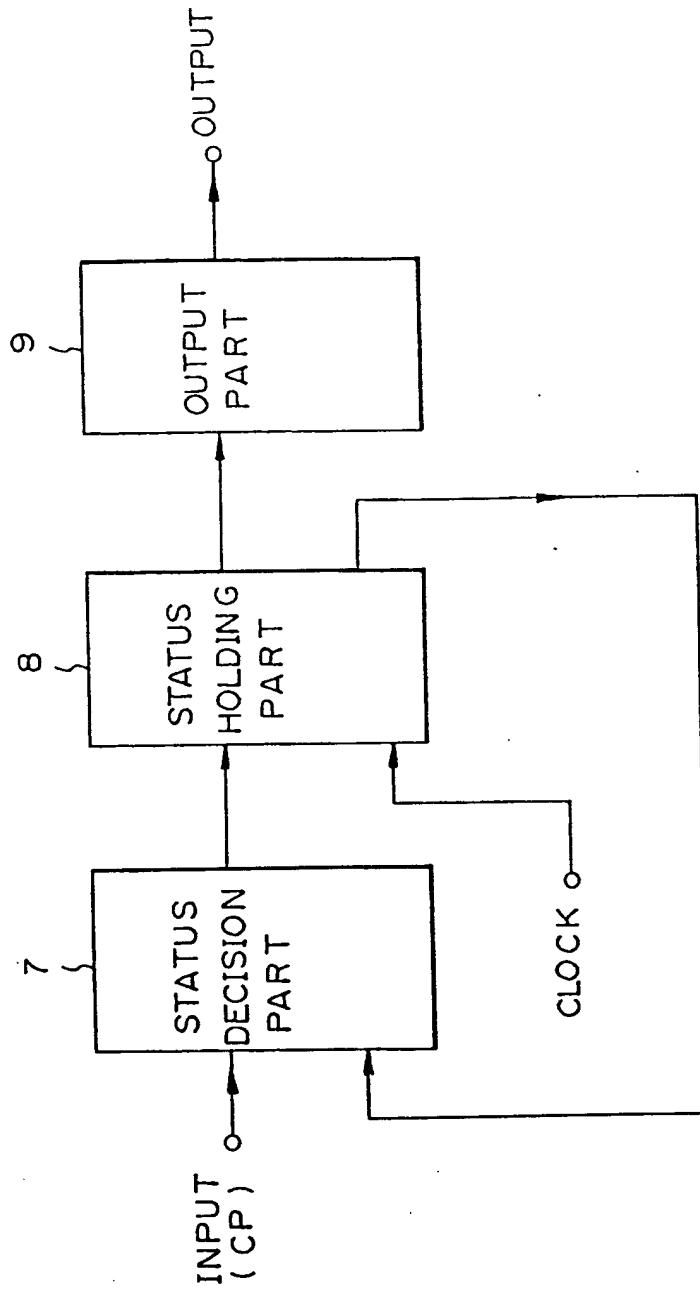



Fig. 6

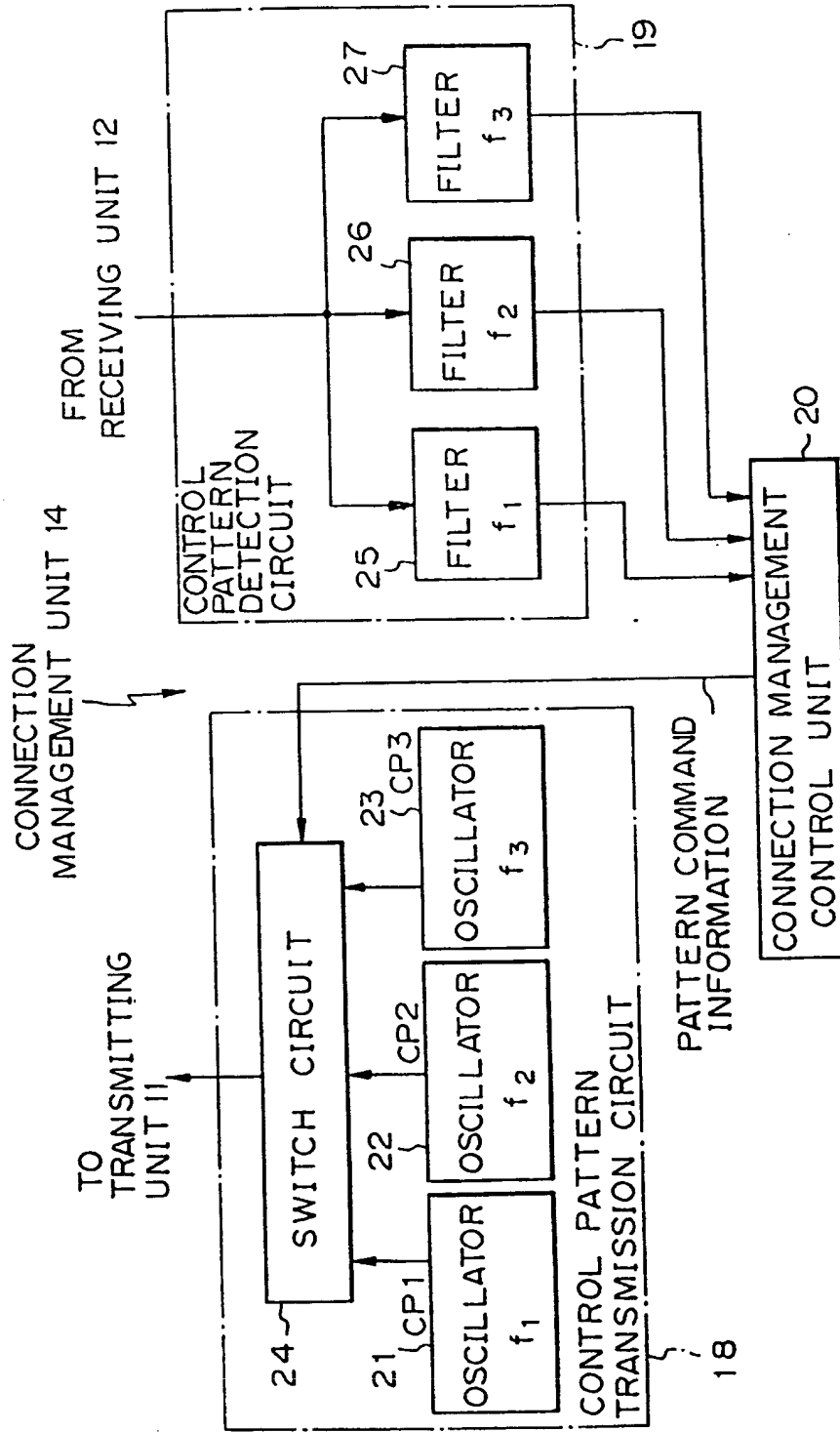

Fig. 7

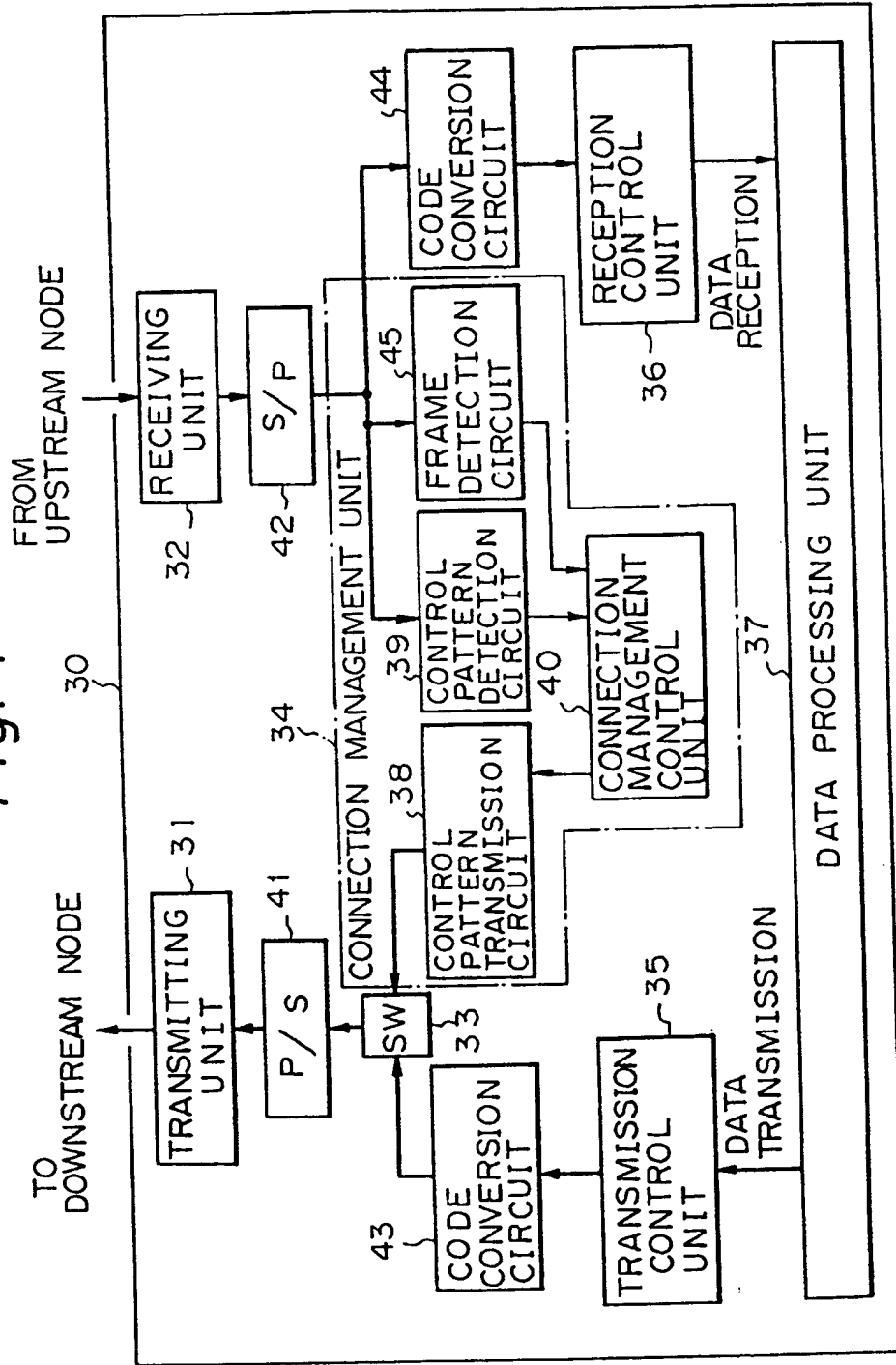

Fig. 8

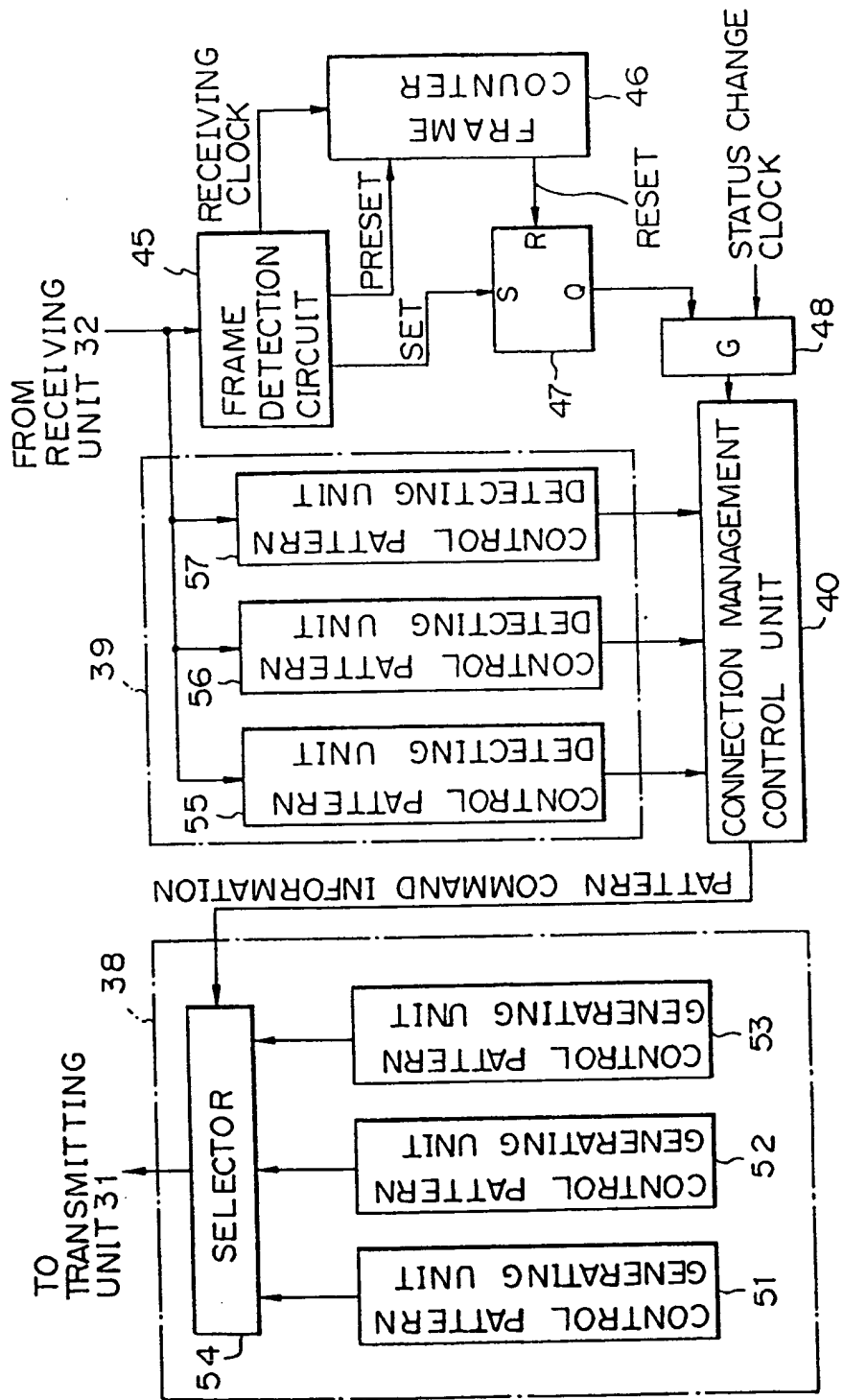
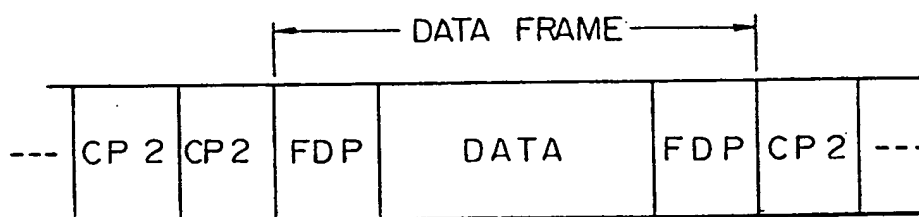

Fig. 9

COMMUNICATION STATUS	MODE OF STATUS	TRANSMITTING PATTERN	RECEIVING PATTERN	NEXT STATUS
S 1	OWN NODE IS IN NORMAL STATUS	CP 1	CP 1	S 2
			CP 2	S 9
S 2	UPSTREAM NODE IS IN NORMAL STATUS	CP 2	CP 3	S 9
			CP 1	S 1
			CP 2	S 3
S 3	CONNECTION CONFIRMING STATUS	CP 2	CP 3	S 9
			CP 1	S 1
			CP 2	S 4
S 4	CONNECTION STATUS	CP 2	CP 3	S 9
			CP 1	S 2
			CP 2	NOT CHANGED
S 5	ABNORMALITY DETECTION STATUS	CP 3	NOT RECEIVED	S 6
S 6	ABNORMALITY STATUS	CP 1	CP 1	S 7
			RECEPTION ERROR CP 2 CP 3	NOT CHANGED
S 7	ABNORMALITY RESTORATION STATUS 1	CP 2	CP 1 CP 2 CP 3	S 8
S 8	ABNORMALITY RESTORATION STATUS 2	CP 2	CP 1 CP 2 CP 3	S 2
S 9	ABNORMALITY WARNING STATUS	CP 3	CP 1 CP 2	S 1

*Fig. 10*



*Fig. 11*

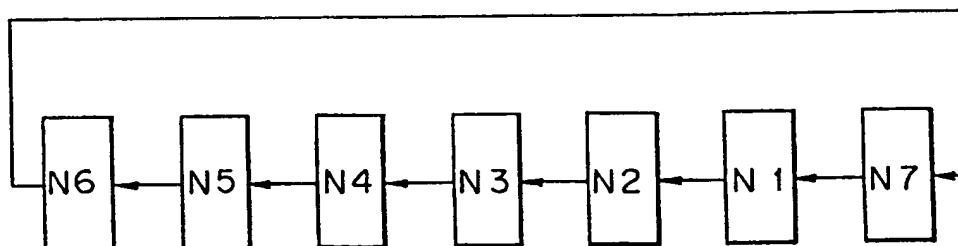

Fig. 12

TERM	N 6	N 5	N 4	N 3	N 2	N 1	N 7
POWER ON.	-	-	-	-	-	-	-
1 T	CP1.S1	CP1.S1	CP1.S1	CP1.S1	CP1.S1	CP1.S1	CP1.S1
2 T	CP2.S2	CP2.S2	CP2.S2	CP2.S2	CP2.S2	CP2.S2	CP2.S2
3 T	CP2.S3	CP2.S3	CP2.S3	CP2.S3	CP2.S3	CP2.S3	CP2.S3
4 T COMPLETION OF CONNECTION	CP2.S4	CP2.S4	CP2.S4	CP2.S4	CP2.S4	CP2.S4	CP2.S4
	CP2.S4	CP2.S4	CP2.S4	CP2.S4	CP2.S4	CP2.S4	CP2.S4

Fig. 13

ABNORMALITY ↑

TERM	N 6	N 5	N 4	N 3	N 2	N 1	N 7
ABNOR- MALITY	CP2·S4	CP2·S4	CP2·S4	CP2·S4	CP2·S4	CP2·S4XCP2·S4	
1 T	CP2·S4	CP2·S4	CP2·S4	CP2·S4	CP2·S4	CP3·S5XCP2·S4	
2 T	CP2·S4	CP2·S4	CP2·S4	CP2·S4	CP3·S9	CP1·S6XCP2·S4	
3 T	CP2·S4	CP2·S4	CP2·S4	CP3·S9	CP1·S1	CP1·S6XCP2·S4	
4 T	CP2·S4	CP2·S4	CP3·S9	CP1·S1	CP2·S2	CP1·S6XCP2·S4	
5 T	CP2·S4	CP3·S9	CP1·S1	CP2·S2	CP1·S1	CP1·S6XCP2·S4	
6 T	CP3·S9	CP1·S1	CP2·S2	CP1·S1	CP2·S2	CP1·S6XCP2·S4	
7 T	CP1·S1	CP2·S2	CP1·S1	CP2·S2	CP1·S1	CP1·S6XCP3·S9	
STOP	CP2·S2	CP1·S1	CP2·S2	CP1·S1	CP2·S2	CP1·S6XCP1·S1	
WORKING	CP1·S1	CP2·S2	CP1·S1	CP2·S2	CP1·S1	CP1·S6XCP2·S2	
REPEAT	CP2·S2	CP1·S1	CP2·S2	CP1·S1	CP2·S2	CP1·S6XCP1·S1	
HEREAFTER	CP2·S2	CP1·S1	CP2·S2	CP1·S1	CP2·S2	CP1·S6XCP1·S1	

Fig. 14

ABNORMALITY

TERM	N 6	N 5	N 4	N 3	N 2	N 1	N 7
ABNORMALITY	CP 2 · S2	CP 1 · S1	CP 2 · S2	CP 1 · S1	CP 2 · S2	CP 1 · S6XCP 1 · S1	
ABNORMALITY	CP 1 · S1	CP 2 · S2	CP 1 · S1	CP 2 · S2	CP 1 · S1	CP 1 · S6XCP 2 · S2	
RESTORATION	CP 2 · S2	CP 1 · S1	CP 2 · S2	CP 1 · S1	CP 2 · S2	CP 1 · S6OCP 1 · S1	
1 T	CP 1 · S1	CP 2 · S2	CP 1 · S1	CP 2 · S2	CP 1 · S1	CP 2 · S7OCP 2 · S2	
2 T	CP 2 · S2	CP 1 · S1	CP 2 · S2	CP 1 · S1	CP 2 · S2	CP 2 · S8OCP 1 · S1	
3 T	CP 1 · S1	CP 2 · S2	CP 1 · S1	CP 2 · S2	CP 2 · S3	CP 2 · S2OCP 2 · S2	
4 T	CP 2 · S2	CP 1 · S1	CP 2 · S2	CP 2 · S3	CP 2 · S4	CP 2 · S3OCP 1 · S1	
5 T	CP 1 · S1	CP 2 · S2	CP 2 · S3	CP 2 · S4	CP 2 · S4	CP 1 · S1OCP 2S2	
6 T	CP 2 · S2	CP 2 · S3	CP 2 · S4	CP 2 · S4	CP 2 · S2	CP 2 · S2OCP 1 · S1	
7 T	CP 2 · S3	CP 2 · S4	CP 2 · S4	CP 2 · S4	CP 2 · S3	CP 1 · S1OCP 2 · S2	
8 T	CP 2 · S4	CP 2 · S4	CP 2 · S4	CP 2 · S4	CP 1 · S1	CP 2 · S2OCP 2 · S3	
9 T	CP 2 · S4	CP 2 · S4	CP 2 · S4	CP 2 · S2	CP 2 · S2	CP 2 · S3OCP 2 · S4	
10 T	CP 2 · S4	CP 2 · S4	CP 2 · S4	CP 2 · S3	CP 2 · S3	CP 2 · S4OCP 2 · S4	
11 T	CP 2 · S4	CP 2 · S4	CP 2 · S4	CP 2 · S4	CP 2 · S4	CP 2 · S4OCP 2 · S4	
RESTART WORKING	CP 2 · S4	CP 2 · S4	CP 2 · S4	CP 2 · S4	CP 2 · S4	CP 2 · S4OCP 2 · S4	



Fig. 15A

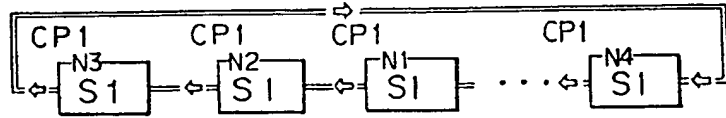

Fig. 15B

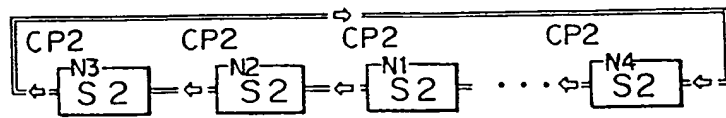

Fig. 15C

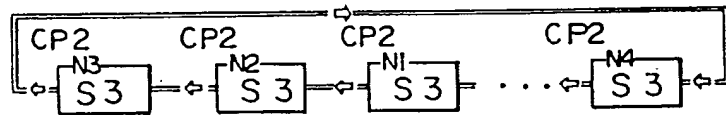

Fig. 15D

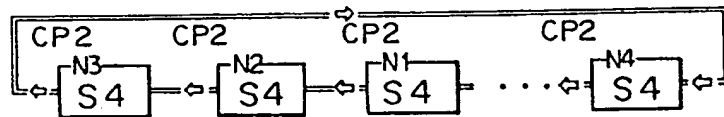

Fig. 15E

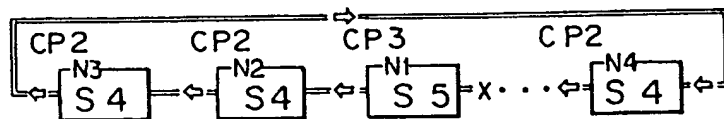

Fig. 15F

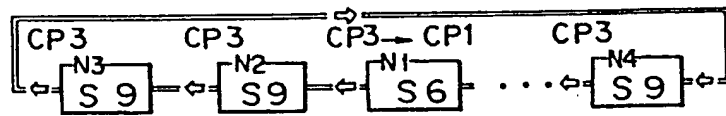

Fig. 15G

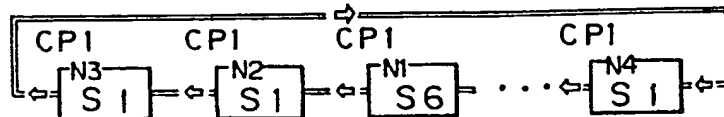

Fig. 15H

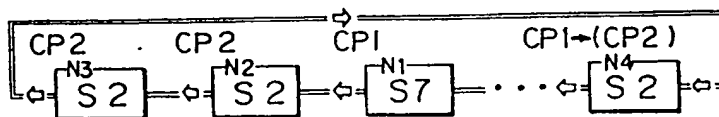

Fig. 15 I

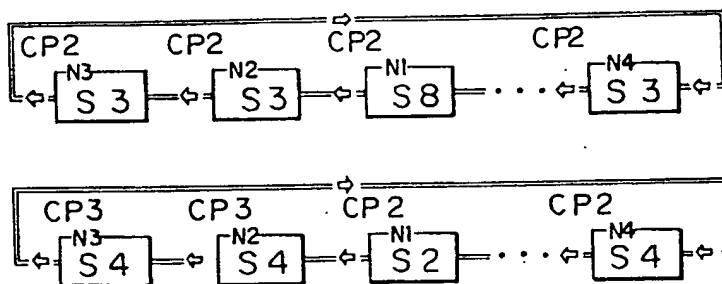

Fig. 15J

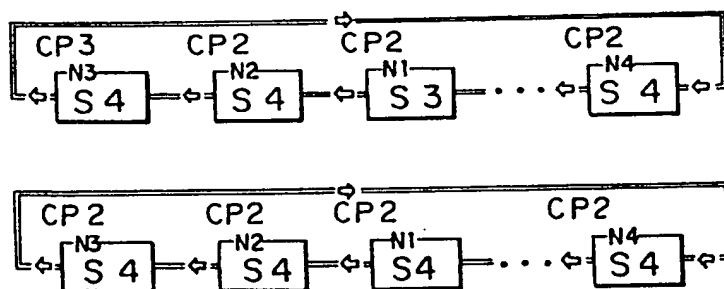

Fig. 16

NO	TRANSMISSION CODES	SINGNIFICANCE
1	0 0 0 1 1	UNUSED
2	0 0 1 0 1	DATA PATTERN 0
3	0 0 1 1 0	DATA PATTERN 1
4	0 1 0 0 1	DATA PATTE RN 2
5	0 1 0 1 0	DATA PATTERN 3
6	0 1 1 0 0	DATA PATTERN 4
7	1 0 0 0 1	DATA PATTERN 5
8	1 0 0 1 0	CONTROL PATTERN (CP1)
9	1 0 1 0 0	DATA PATTERN 6
10	1 1 0 0 0	CONTROL PATTERN (CP2)
11	0 0 1 1 1	DATA PATTERN 7
12	0 1 0 1 1	DATA PATTERN 8
13	0 1 1 0 1	DATA PATTERN 9
14	0 1 1 1 0	DATA PATTERN 10
15	1 0 0 1 1	DATA PATTERN 11
16	1 0 1 0 1	DATA PATTERN 12
17	1 0 1 1 0	DATA PATTERN 13
18	1 1 0 0 1	DATA PATTERN 14
19	1 1 0 1 0	CONTROL PATTERN (CP3)
20	1 1 1 0 0	DATA PATTERN 15
21	0 0 0 0 0	FRAME DELIMITER PATTERN (FDP)
22	0 0 0 0 1	TOKEN PATTERN

**This Page is Inserted by IFW Indexing and Scanning  
Operations and is not part of the Official Record**

**BEST AVAILABLE IMAGES**

Defective images within this document are accurate representations of the original documents submitted by the applicant.

Defects in the images include but are not limited to the items checked:

- BLACK BORDERS**
- IMAGE CUT OFF AT TOP, BOTTOM OR SIDES**
- FADED TEXT OR DRAWING**
- BLURRED OR ILLEGIBLE TEXT OR DRAWING**
- SKEWED/SLANTED IMAGES**
- COLOR OR BLACK AND WHITE PHOTOGRAPHS**
- GRAY SCALE DOCUMENTS**
- LINES OR MARKS ON ORIGINAL DOCUMENT**
- REFERENCE(S) OR EXHIBIT(S) SUBMITTED ARE POOR QUALITY**
- OTHER:** \_\_\_\_\_

**IMAGES ARE BEST AVAILABLE COPY.**

**As rescanning these documents will not correct the image problems checked, please do not report these problems to the IFW Image Problem Mailbox.**